

Panasonic

Operating Instructions

Compact Plain Paper Fax with DECT

Model No. **KX-FC255AL**

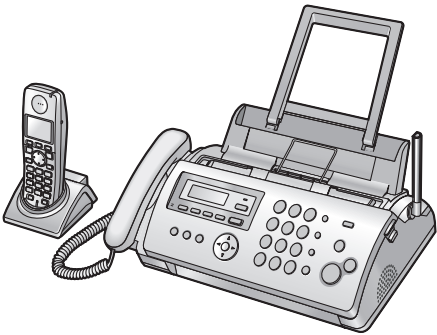

Please read these operating instructions before using the unit and save for future reference.

Charge the battery for about 7 hours before initial use.

This unit is compatible with Caller ID and SMS. To use these features, you must subscribe to the appropriate service of your service provider.

Be sure to use the telephone line cord included in this unit.

This model is designed to be used only in Australia.

Warning:

- Please ensure that a separate telephone, not dependent on local power, is available for emergency use.
- This equipment will be inoperable when mains power fails.
- When a failure occurs which results in the internal parts becoming accessible, disconnect the power supply cord immediately and return this unit to an authorised service centre.
- Disconnect the telephone connection before disconnecting power connection prior to relocating the equipment, and reconnect the power first.
- To minimize the possibility of lightning damage, when you know that a thunderstorm is coming, we recommend that you:
 - A. Unplug the telephone line cord from the phone jack.
 - B. Unplug the power supply cord from the AC power outlet.
- No "000" or other calls can be made from this device during a mains power failure.
- The earcap on the handset is magnetised and may retain metallic objects.

Important information

Instructions to customer

Installation

Attached to this apparatus is an approval label. This label is evidence that it is a "Permitted Attachment" which has been authorised to be connected to your telephone service.

Conditions relating to connection and operation of this Permitted Attachment are contained in Telecommunications General By-Law 220 (5).

You are authorised to install this Permitted Attachment yourself by plugging it into the line socket of any regular telephone. You may connect it in place of your existing telephone or to any spare telephone socket installed in your premises.

To disconnect your existing telephone you must first remove its plug from the line socket. You can then insert the plug of your Permitted Attachment into the socket and use your equipment.

If the plug of your existing telephone cannot be readily removed, you will have to remove the screw securing it. To do this proceed as follows:

1. Loosen screw "A" sufficiently to remove the socket cover. (See Fig. 1.)
2. Remove screw "B" and withdraw the plug. (See Fig. 2.)
3. Replace screw "B". (See Fig. 3.) Ensure that it screws completely into the socket recess. (If the screw is too long, increase the hole depth or replace the screw with one 5 mm shorter.)
4. Replace socket cover and tighten screw "A". (See Fig. 4.)

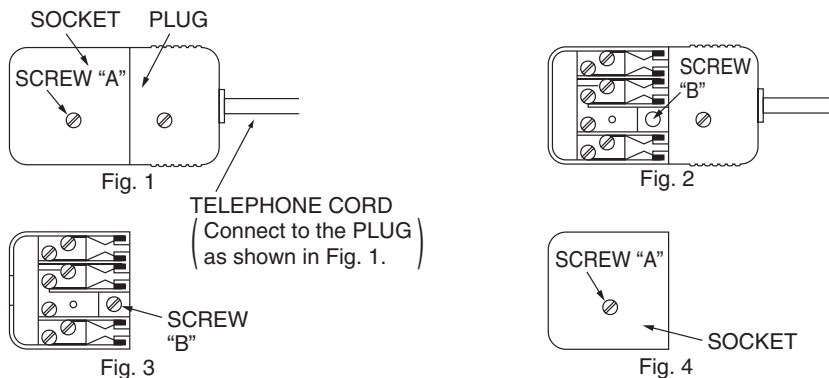

If you are satisfied with the operation of your telephone service after plugging in your Permitted Attachment, your installation is completed.

You will be unable to connect this Permitted Attachment if your telephone service consists only of a wall phone or an old style telephone which is not connected by means of a modern plug and socket. In such cases a new socket will need to be installed.

Should the Permitted Attachment not operate when plugged into a socket, it is either faulty or unsuitable for operation with your telephone service. It should be returned to the store where purchased.

Service difficulties

If at any time a fault occurs on your telephone service carry out the following checks before you call for service:

- Disconnect the Permitted Attachment and try using the service with the normal telephone.
- If the telephone service then operates satisfactorily, the fault is in your Permitted Attachment. Leave the Permitted Attachment disconnected and report the fault to its supplier or agent to arrange for repair.
- If when using the telephone the service is still faulty, report the fault to "Service Difficulties and Faults" for attention.

You are required to keep this Permitted Attachment in good working order while it is connected to your telephone service. Its construction or internal circuit must not be modified in any way without permission.

WARNING

This cordless telephone system does not incorporate provision for secrecy of conversations. Appropriately tuned radio equipment and other cordless telephone systems in close proximity may be used by a third party to monitor and possibly interrupt conversations in progress when this system is on radio operation.

Important safety instructions

When using this unit, basic safety precautions should always be followed to reduce the risk of fire, electric shock, or personal injury.

1. Read and understand all instructions.
2. Follow all warnings and instructions marked on this unit.
3. Unplug this unit from power outlets before cleaning. Do not use liquid or aerosol cleaners.
4. Do not use this unit near water, for example near a bathtub, wash bowl, kitchen sink, etc.
5. Place the unit securely on a stable surface. Serious damage and/or injury may result if the unit falls.
6. Do not cover slots and openings on the unit. They are provided for ventilation and protection against overheating. Never place the unit near radiators, or in a place where proper ventilation is not provided.
7. Use only the power source marked on the unit. If you are not sure of the type of power supplied to your home, consult your dealer or local power company.
8. For safety purposes this unit is equipped with a grounded plug. If you do not have this type of outlet, please have one installed. Do not defeat this safety feature by tampering with the plug.
9. Do not place objects on the power cord. Install the unit where no one can step or trip on the cord.
10. Do not overload power outlets and extension cords. This can result in the risk of fire or electric shock.
11. Never push any objects through slots in this unit. This may result in the risk of fire or electric shock. Never spill any liquid on the unit.
12. To reduce the risk of electric shock, do not disassemble this unit. Take the unit to an authorised service centre when service is required. Opening or removing covers may expose you to dangerous voltages or other risks. Incorrect reassembly can cause electric shock when the unit is subsequently used.
13. Unplug this unit from power outlets and refer servicing to an authorised service centre when the following conditions occur:
 - A. When the power cord is damaged or frayed.
 - B. If liquid has been spilled into the unit.
 - C. If the unit has been exposed to rain or water.
 - D. If the unit does not work normally by following the operating instructions. Adjust only controls covered by the operating instructions. Improper adjustment may require extensive work by an authorised service centre.
 - E. If the unit has been dropped or physically damaged.
 - F. If the unit exhibits a distinct change in performance.
14. During thunderstorms, avoid using telephones except cordless types. There may be a remote risk of an electric shock from lightning.

15. Do not use this unit to report a gas leak, when in the vicinity of the leak.
16. It is advised not to use the equipment at a refuelling point. Users are reminded to observe restrictions on the use of radio equipment in fuel depots, chemical plants or where blasting operations are in progress.

SAVE THESE INSTRUCTIONS

CAUTION:

Installation

- Never install telephone wiring during a lightning storm.
- Never install telephone jacks in wet locations unless the jack is specifically designed for wet locations.
- Never touch uninsulated telephone wires or terminals unless the telephone line has been disconnected at the network interface.
- Use caution when installing or modifying telephone lines.
- Do not touch the plug with wet hands.
- This unit should not be used near emergency/intensive care medical equipment and should not be used by people with pacemakers.

Battery

To reduce the risk of fire or injury to persons, read and follow these instructions.

- Use only the battery(ies) specified.
- Do not mix old and new batteries.
- Do not dispose of the battery(ies) in a fire. They may explode. Check with local waste management codes for special disposal instructions.
- Do not open or mutilate the battery(ies). Released electrolyte is corrosive and may cause burns or injury to the eyes or skin. The electrolyte may be toxic if swallowed.
- Exercise care when handling the battery(ies). Do not allow conductive materials such as rings, bracelets or keys to touch the battery(ies), otherwise a short circuit may cause the battery(ies) and/or the conductive material to overheat and cause burns.
- Charge the battery(ies) provided with or identified for use with this product only in accordance with the instructions and limitations specified in this manual.
- Only use the included charger to charge the battery(ies). Do not tamper with the charger. Failure to follow these instructions may cause the battery(ies) to swell or explode.
- Only use rechargeable battery(ies). If you install non-rechargeable battery(ies) and start charging them, the battery(ies) may leak electrolyte.

WARNING:

- To prevent the risk of fire or electrical shock, do not expose this product to rain or any type of moisture.

- Unplug this unit from power outlets if it emits smoke, an abnormal smell or makes unusual noise. These conditions can cause fire or electric shock. Confirm that smoke has stopped and contact an authorised service centre.

For Best Performance

Location and noise

The base unit and cordless handset use radio waves to communicate with each other. For maximum distance and noise-free operation, we recommend the following:

- Placing the unit away from electrical appliances such as a TV, personal computer or another cordless phone.
- Placing the unit in a HIGH and CENTRAL location with no obstructions such as walls.
- Raising the antenna vertically.

Environment

- Keep the unit away from electrical noise generating devices, such as fluorescent lamps and motors.
- The unit should be kept free from dust, high temperature and vibration.
- The unit should not be exposed to direct sunlight.
- Do not place heavy objects on top of the unit.
- When you leave the unit unused for a long period of time, unplug this unit from power outlet.
- The unit should be kept away from heat sources such as heaters, kitchen stoves, etc. Damp basements should also be avoided.

Routine care

- Wipe the outer surface of the unit with a soft cloth. Do not use benzine, thinner, or any abrasive powder.

1. Introduction and Installation

Accessories

- 1.1 Included accessories 9
- 1.2 Accessory information 9

Finding the Controls

- 1.3 Button descriptions of the base unit 10
- 1.4 Button descriptions of the cordless handset 11
- 1.5 Display descriptions of the cordless handset .. 11
- 1.6 Overview 13

Installation

- 1.7 Ink film 14
- 1.8 Paper tray 15
- 1.9 Recording paper 16
- 1.10 Handset cord 16
- 1.11 Battery installation / replacement 16

2. Preparation

Connections and Setup

- 2.1 Connections 17
- 2.2 Battery charge 18
- 2.3 Cordless handset screen saver mode 18
- 2.4 Turning the cordless handset power ON/OFF . 18

Volume

- 2.5 Adjusting cordless handset volume 19
- 2.6 Adjusting base unit volume..... 19

Initial Programming

- 2.7 Date and time 20
- 2.8 Your logo..... 21
- 2.9 Your fax number 21

3. Telephone

Making and Answering Calls

- 3.1 Making phone calls..... 22
- 3.2 Answering phone calls..... 23
- 3.3 Using the recall feature..... 24
- 3.4 Recording a telephone conversation (Cordless handset only)..... 24
- 3.5 Night mode 24

Automatic Dialling

- 3.6 Cordless handset phonebook..... 25
- 3.7 Chain dial (Cordless handset only) 26
- 3.8 Base unit phonebook..... 26
- 3.9 One touch dial 27

Caller ID

- 3.10 Caller ID service 28
- 3.11 Viewing and calling back 29
- 3.12 Editing a caller's telephone number before calling back..... 30
- 3.13 Erasing caller information 30
- 3.14 Storing caller information into the phonebook . 31

SMS (Short Message Service)

- 3.15 Using SMS (Short Message Service)31
- 3.16 Turning SMS ON/OFF31
- 3.17 Changing SMS message centre numbers ...32
- 3.18 Registering mailboxes32
- 3.19 Sending a message32
- 3.20 Receiving a message.....33
- 3.21 Guide to SMS settings33

4. Fax

Sending Faxes

- 4.1 Sending a fax manually35
- 4.2 Document requirements.....36
- 4.3 Sending a fax using the phonebook and one touch dial.....36
- 4.4 Broadcast transmission.....37

Receiving Faxes

- 4.5 Selecting the way to use your fax machine ..38
- 4.6 Receiving a fax manually – Auto answer OFF . 39
- 4.7 Receiving a fax automatically – Auto answer ON.....40
- 4.8 Receive polling (retrieving a fax placed on another fax machine)41
- 4.9 Junk fax prohibitor (preventing fax reception from undesired callers).....41

5. Distinctive Ring

Distinctive Ring

- 5.1 Using with the ring detection feature.....42

6. Copy

Copying

- 6.1 Making a copy43

7. Answering Machine

Greeting

- 7.1 Recording your greeting message45

Incoming Messages

- 7.2 Listening to recorded messages46

Memo Message

- 7.3 Leaving a message for others or yourself ...46

Remote Operation

- 7.4 Using the answering machine with the cordless handset47
- 7.5 Operating from a remote location.....48

8. Programmable Features

Base Unit

- 8.1 Base unit programming50

Cordless Handset

- 8.2 Cordless handset programming56

9. Multi-unit Operation

Additional Units

- 9.1 Operating additional units..... **59**
- 9.2 Registering a cordless handset to a base unit
59

Other Features

- 9.3 Intercom **60**
- 9.4 Transferring a call/conference **60**
- 9.5 Copying phonebook items **61**

10. Useful Information

Useful Information

- 10.1 Character entry..... **62**

11. Help

Error Messages

- 11.1 Error messages – Reports **64**
- 11.2 Error messages – Display **65**

Troubleshooting

- 11.3 When a function does not work, check here **67**

12. Maintenance

Jams

- 12.1 Recording paper jams **74**
- 12.2 Document jams **75**

Cleaning

- 12.3 Document feeder/recording paper feeder/
scanner glass cleaning **76**
- 12.4 Thermal head cleaning..... **77**

13. General Information

Printed Reports

- 13.1 Reference lists and reports (Base unit only) **78**

Specifications

- 13.2 Specifications **78**

14. Index

- 14.1 Index..... **80**

1.1 Included accessories

- ① Telephone line cord
(Modular type plug)



- ② Handset



- ③ Handset cord*¹

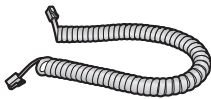

- ④ Paper tray
① Paper support
② Paper tray

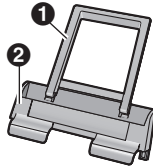

- ⑤ Starter ink film
(10 metres long)



- ⑥ Cordless handset



- ⑦ Rechargeable batteries ⑧ AC adaptor
(PQLV209EZ)*¹



- ⑨ Charger



- ⑩ Operating instructions



- ⑪ Quick installation guide

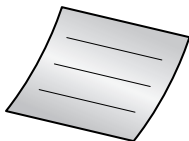

*¹ Part numbers are subject to change without notice.

Note:

- If any items are missing or damaged, contact the place of purchase.
- Save the original carton and packing materials for future shipping and transportation of the unit.

1.2 Accessory information

Additional/replacement accessories

- **Replacement film*¹** (Model No./Part No. **KX-FA52E**): 30 m × 2 rolls (Each roll will print about 90 A4-sized pages.)
- **Rechargeable batteries*²** (Model No./Part No. **P03P**): 2 rechargeable nickel metal hydride (Ni-MH) batteries, AAA (R03) size
- **Additional digital cordless handset** (Model No./Part No. **KX-TGA810AZ**)

*¹ To ensure the unit operates properly, we recommend using the Panasonic replacement film. **The ink film is not reusable. Do not rewind and use the ink film again.**

*² Maximum capacity of 750mAh

1.3 Button descriptions of the base unit

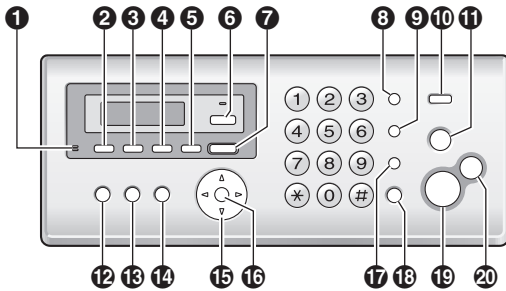

- 1 [MIC] (Microphone)**
 - The built-in microphone.
- 2 [GREETING REC]**
 - To record a greeting message (page 45).
- 3 [GREETING CHECK]**
 - To check a greeting message (page 45).
- 4 [MEMO]**
 - To record a memo message (page 46).
- 5 [ERASE]**
 - To erase messages (page 45, 46).
- 6 [AUTO ANSWER]**
 - To turn the auto answer setting ON/OFF (page 39, 40).
- 7 [PLAYBACK]**
 - To play messages (page 46).
- 8 [REDIAL][PAUSE]**
 - To redial the last number dialed from the base unit.
 - To insert a pause during dialling.
- 9 [RECALL]**
 - To access special telephone services such as call waiting (page 24) or for transferring extension calls.
 - The recall/flash time can be changed (feature #72 on page 55).
- 10 [CALLER ID]**
 - To use Caller ID features (page 28).
- 11 [STOP]**
 - To stop an operation or programming session.
 - To erase a character/number (page 62). Press and hold to erase all characters/numbers.
- 12 [LOCATOR][INTERCOM]**
 - To make/answer intercom calls (page 60).
 - To page or locate a cordless handset (page 60).
- 13 [PRINT REPORT]**
 - To print lists and reports for reference purposes (page 78).
- 14 [MENU]**
 - To start or exit programming.
- 15 [PHONEBOOK][VOLUME]**
 - To adjust volume (page 19).
 - To search for a stored item (page 26, page 36).
- 16 [SET]**
 - To store a setting during programming.
- 17 [MUTE]**
 - To mute your voice during a conversation. Press again to resume the conversation.
- 18 [SP-PHONE]**
 - For speakerphone operation.
- 19 [FAX START]**
 - To send or receive a fax.
- 20 [COPY]**
 - To copy a document (page 43).

1.4 Button descriptions of the cordless handset

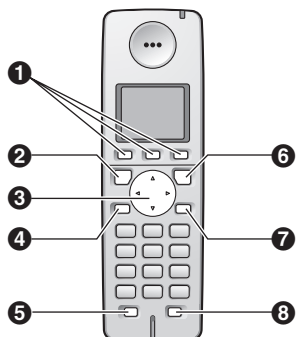

1 Soft keys

- To select the features or operations displayed directly above each key (page 12).

2 [↶] (Talk)

- To make/answer calls (page 22, 23).

3 Navigator

- To adjust volume (page 19).
- To search for a stored item (page 26).
- To select features or feature settings during programming.
- To navigate to the next operation.

4 [☎] (Speakerphone)

- For speakerphone operation.

5 [R] (Recall)

- To access special telephone services such as call waiting (page 24) or for transferring extension calls.
- The recall/flash time can be changed (feature #72 on page 55).

6 [⏻] (Off/Power)

- To turn power ON/OFF (page 18).
- To hang up (page 22, 23).
- To stop an operation or programming.

7 [C/⊗] (Clear/Mute)

- To mute your voice during a conversation. Press again to resume the conversation.
- To erase a character/number (page 62). Press and hold to erase all characters/numbers.

8 [INT] (Intercom)

- To page or locate the base unit or another cordless handset (page 60).

1.5 Display descriptions of the cordless handset

Display icons

Display icon	Meaning
	Within range of a base unit <ul style="list-style-type: none"> When flashing: Cordless handset is searching for base unit (out of range of base unit, cordless handset is not registered to base unit, no power on base unit)
	Cordless handset is accessing base unit (intercom, paging, changing base unit settings, etc.)
	Cordless handset is on an outside call
	Missed call ⁺¹ (page 29)
	Answering machine is ON (page 40) and/or new messages have been recorded (page 47)
	Answering machine is full.
	Answering machine answers calls with a greeting message (page 48)
	Batteries are charging
	Battery strength
	Alarm is ON (page 58)
	Voice enhancer is set to high or low tone (page 22)
	Ringer volume is OFF (page 19)
	Night mode is ON (page 24)
"[2]"	Cordless handset number (standby display setting, page 56)
"-2-"	Base unit number (standby display setting, page 56)
	New SMS message received ⁺² (page 33)
	Your written SMS message is over 160 characters ⁺² (page 32)
	SMS memory is full ⁺²
	<ul style="list-style-type: none"> Line is being used by the base unit or another cordless handset Answering machine is being used by another cordless handset or the base unit







1. Introduction and Installation

*1 Caller ID subscribers only

*2 SMS users only

Menu icons

When in standby mode, pressing the middle soft key reveals the cordless handset's main menu. From here you can access various features and settings.







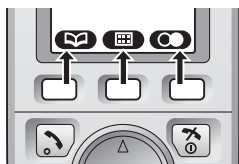



Menu icon	Menu/feature
	"Caller List"
	"SMS" (Short Message Service)
	"Answer System"
	"Handset Setup"
	"Base Unit Setup"
	"Display Setup"

Soft keys

The cordless handset features 3 soft keys. By pressing a soft key, you can select the feature or operation indicated by the soft key icon shown directly above it.



Soft key icons

Soft key icon	Action
	Returns to the previous screen
	Displays the menu
	Accepts the current selection
	Displays a previously dialed phone number
	Opens the cordless handset phonebook
	Displays the phonebook search menu
	Turns the key lock feature OFF (page 22)
	Displayed when adding or editing a phonebook item, or when writing an SMS message
	Stops recording or playback
	Inserts a pause during dialling
	Erases the selected item

Soft key icon	Action
	Displayed when the soft key has no function

1.6 Overview

1.6.1 Base unit

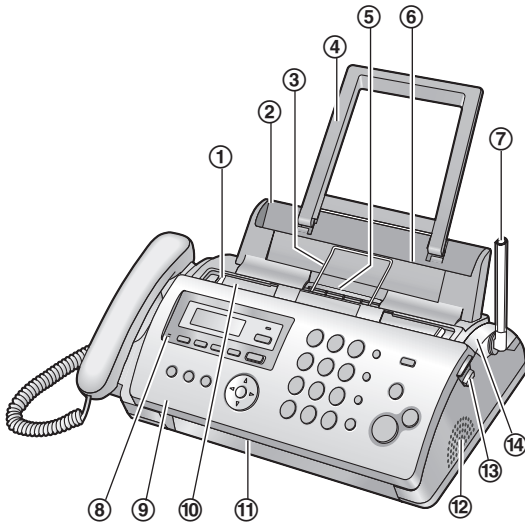

- ① Document guides
- ② Paper tray
- ③ Metal recording paper guide
- ④ Paper support
- ⑤ Recording paper exit
- ⑥ Recording paper entrance
- ⑦ Antenna
- ⑧ Microphone
- ⑨ Front cover
- ⑩ Document entrance
- ⑪ Document exit
- ⑫ Speaker
- ⑬ Green button (Back cover release button)
- ⑭ Back cover

Removing the shipping tape

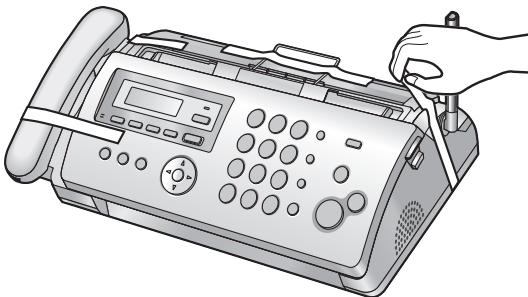

1.6.2 Cordless handset

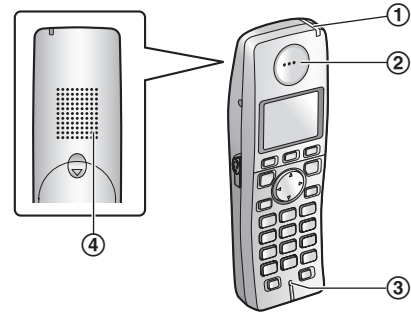

- ① Charge indicator
- Ringer indicator
- Message indicator
- ② Receiver
- ③ Microphone
- ④ Speaker

1.7 Ink film

The included film roll is a starter ink film.

- 1 Open the front cover.

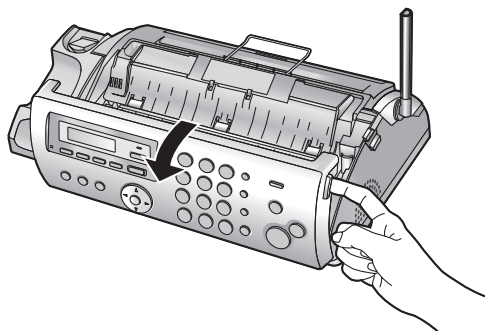

- 2 Release the back cover by pushing the green button (1).

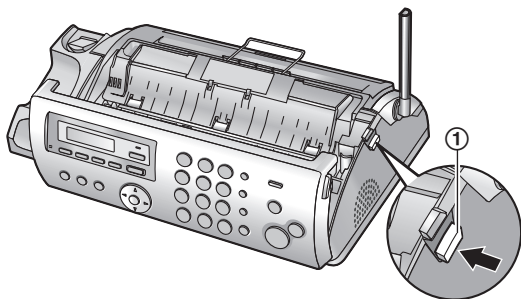

- 3 Open the back cover.

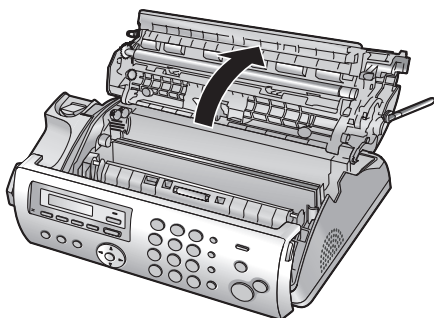

- 4 Insert the blue gear of the ink film roll into the front left slot of the unit (2) and the white gear of the ink film roll into the rear left slot of the unit (3).

- The ink film is safe to touch and will not rub off on your hands like carbon paper.

- Make sure the blue gear (2) and white gear (3) are installed as shown.

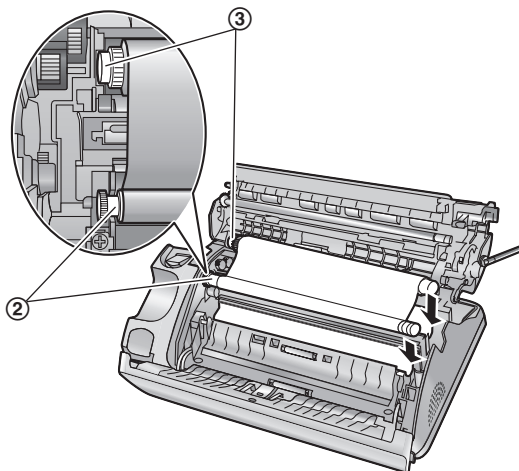

- 5 Turn the blue gear (4) in the direction of the arrow until the ink film is tight (5) and at least one layer of ink film is wrapped around the blue core (6).

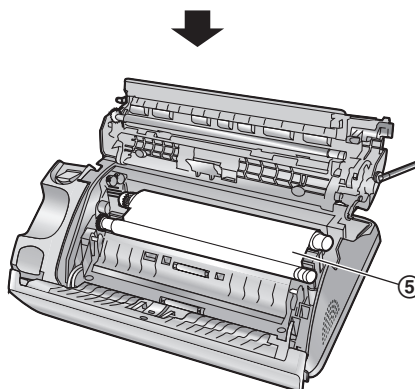
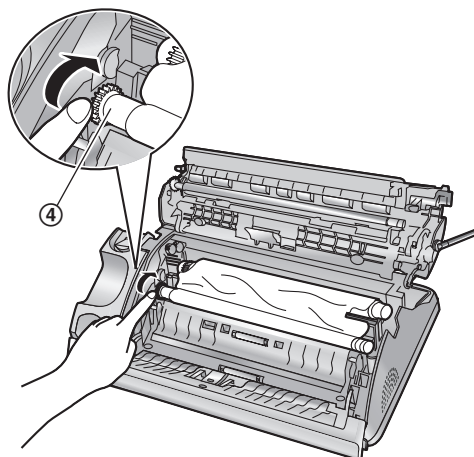

Correct

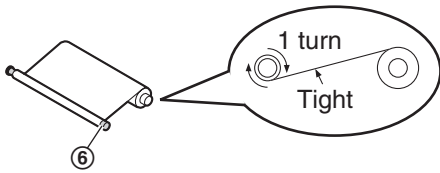

Incorrect

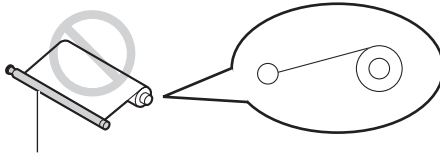

No ink film is wrapped around the blue core.



- 6** Close the back cover securely by pushing down on the dotted area at both ends (7).

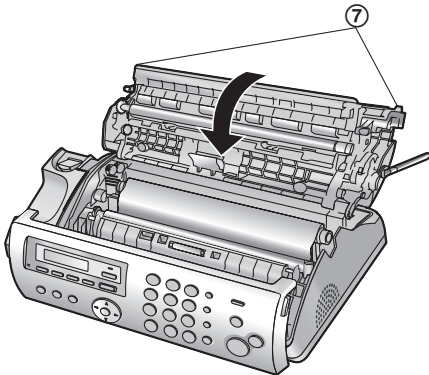

- 7** Close the front cover securely.

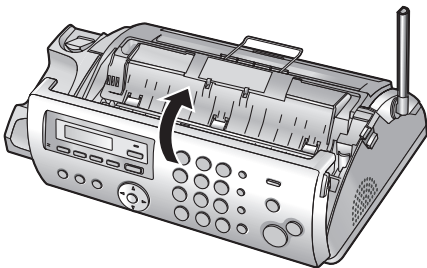

1.8 Paper tray

Pull up the metal recording paper guide (1), then install the paper tray (2).

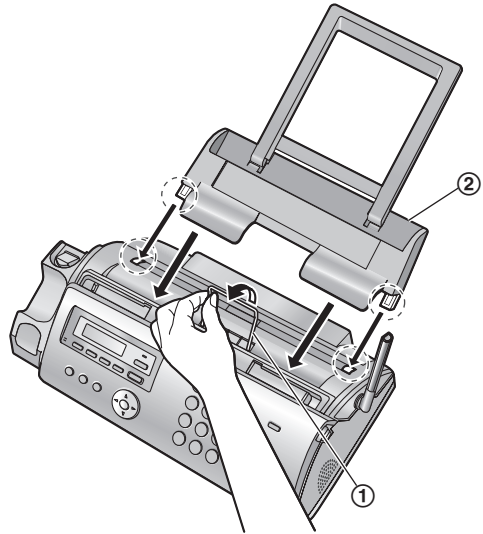

- Make sure the arrows on the paper tray and the unit match.

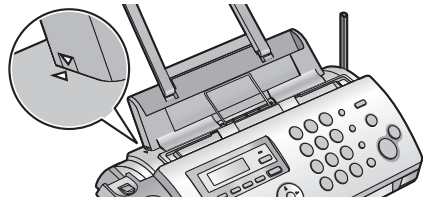

- If the paper support is folded, unfold it.

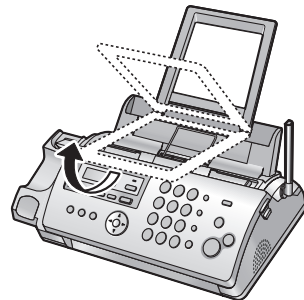

1.9 Recording paper

The unit can hold up to 20 sheets of 64 g/m² to 80 g/m² paper.

Please refer to page 79 for more information on recording paper.

- 1 Fan the paper to prevent paper jams.

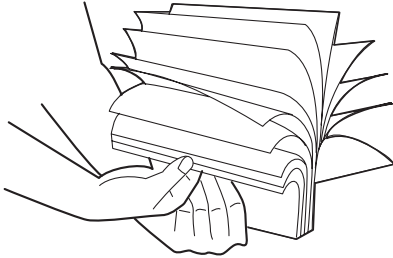

- 2 Insert the paper gently, print-side down (①).
 - Do not force the paper into the paper tray.

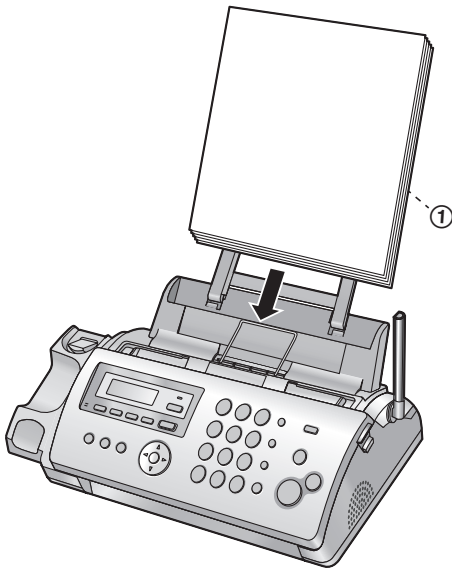

- If the paper is not inserted correctly, remove all of the installed paper, and re-install it gently. Otherwise the paper may jam.

Correct

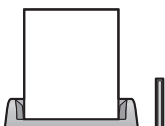

Slant



Note:

- Remove all of the installed paper before adding paper.

1.10 Handset cord

Connect the handset cord (①).

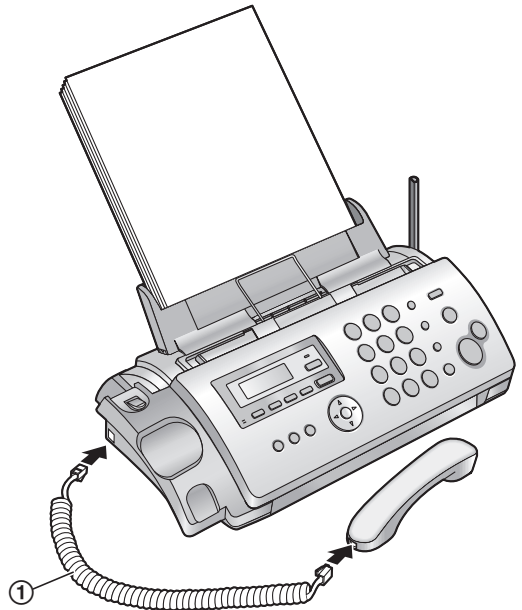

1.11 Battery installation / replacement

Important:

- Use only the included rechargeable batteries noted on page 5, 9.
 - When replacing batteries, we recommend using the Panasonic rechargeable batteries noted on page 5, 9.
- 1 Press the notch on the cordless handset cover firmly, and slide the cover.
 - When replacing batteries, remove the old batteries positive (⊕) terminal first.

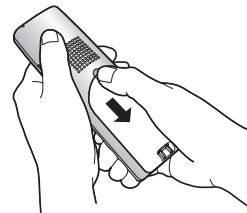

- 2 Insert the batteries negative (⊖) terminal first. Close the cordless handset cover.

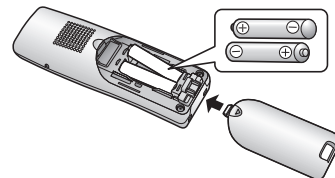

2.1 Connections

Important:

- The unit will not function when there is a power failure. To make calls in emergency situations, you should connect a telephone that can function during a power failure to the telephone line.

2.1.1 Base unit

- ① Telephone line cord
 - Connect to a single telephone line jack.
- ② Power cord
 - Connect to a power outlet (220 V – 240 V, 50/60 Hz).

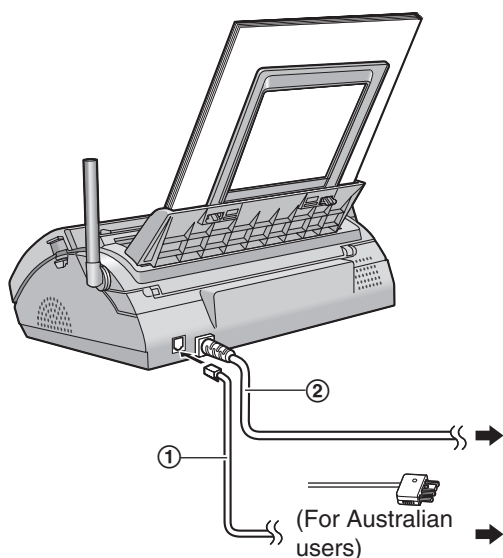

Caution:

- When you operate this product, the power outlet should be near the product and easily accessible.
- Be sure to use the telephone line cord included in this unit.
- Do not extend the telephone line cord.

Note:

- If any other device is connected to the same telephone line, this unit may disturb the network condition of the device.

- If you use the unit with a computer and your internet provider instructs you to install a filter (③), please connect the telephone line cord of the unit.

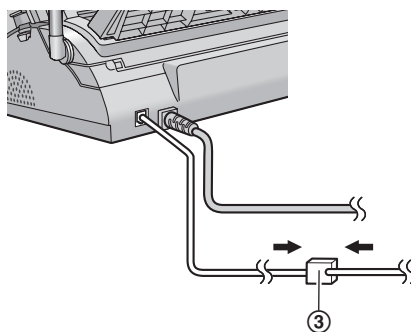

2.1.2 Charger unit

- ① AC adaptor
 - Connect to a power outlet (220 V – 240 V, 50/60 Hz).
- ② Hooks
 - Fasten the AC adaptor cord to prevent it from being disconnected.
- ③ Screws (not included)
 - The charger can be mounted on the wall, if required.

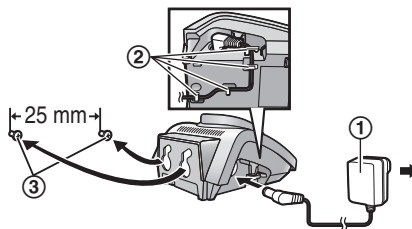



Caution:

- **USE ONLY WITH** the included Panasonic AC adaptor.
- The AC adaptor must remain connected at all times. (It is normal for the adaptor to feel warm during use.)
- The AC adaptor should be connected to a vertically oriented or floor-mounted AC outlet. Do not connect the AC adaptor to a ceiling-mounted AC outlet, as the weight of the adaptor may cause it to become disconnected.

2.2 Battery charge

Place the cordless handset on the charger for about **7 hours** before initial use.

When charging,  and battery strength icon are alternately shown on the display.

When the batteries are fully charged,  remains on the display.

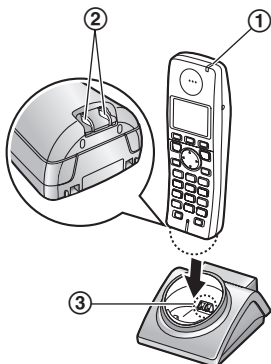

- The charge indicator (①) lights up when the cordless handset is placed on the charger.



Note:

- To ensure the battery charges properly, clean the charge contacts of the cordless handset (②) and the charger (③) with a soft, dry cloth once a month. Clean more often if the unit is subject to grease, dust, or high humidity.

Battery strength

Battery icon	Battery strength
	High
	Medium
	Low When flashing: Needs to be charged.

Panasonic Ni-MH battery performance (included batteries)

Operation	Operating time
In continuous use	12 hours max.
In continuous standby mode	150 hours max.

Note:

- It is normal for batteries not to reach full capacity at the initial charge. Maximum battery performance is reached after a few complete cycles of charge/discharge (use).
- Actual battery performance depends on a combination of how often the cordless handset is in use and how often it is not in use (standby).

- Battery operating time may be shortened over time depending on usage conditions and ambient temperature.
- Even after the cordless handset is fully charged, the cordless handset can be left on the charger without any ill effect on the batteries.
- The battery strength may not be displayed correctly after you replace the batteries. In this case, place the cordless handset on the charger and charge for at least 7 hours.

2.3 Cordless handset screen saver mode

The backlight will turn **OFF completely** after **1 minute of inactivity** if the cordless handset is not on the charger.

To use the cordless handset when it is in screen saver mode, first press  to turn the display ON again.

2.4 Turning the cordless handset power ON/OFF

Power ON

Press  for about 1 second.

Power OFF

Press  for about 2 seconds.

2.5 Adjusting cordless handset volume

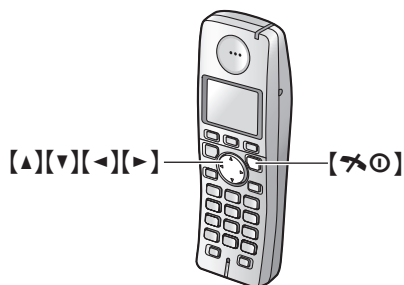

Ringer volume

- 1.
2. Select by pressing [▲], [▼], [◀], or [▶]. → **OK**
3. Press [▲] or [▼] to select "Ringer Setup". → **OK**
4. Press [▲] or [▼] to select "Ringer Volume". → **OK**
5. Press [▲] or [▼] to select the desired volume. → **OK** → [🔊]

Note:

- When the ringer volume is turned OFF, is displayed.
When the ringer is turned OFF, the cordless handset will ring:
 - at the minimum level for alarm and intercom calls
 - at the maximum level for paging

Ringtone

You can select the desired cordless handset ringtone for outside calls and intercom calls (page 56). Caller ID service users can also use a different ringer for each category (page 29).

Cordless handset receiver volume

While using the receiver, press [▼] or [▲].

Speaker volume

While using the speakerphone, press [▼] or [▲].

2.6 Adjusting base unit volume

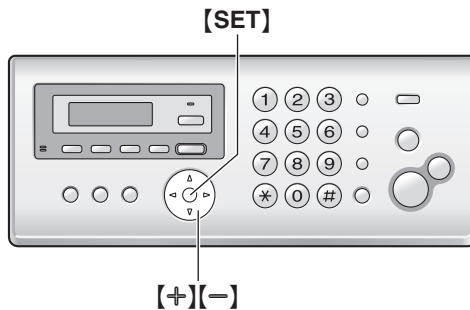

Ringer volume

While the unit is idle, press [+] or [-].

- If there are any documents in the document entrance, you cannot adjust the volume. Confirm that there are no documents in the entrance.

To turn the ringer OFF

Press [-] repeatedly to display "RINGER OFF= OK?". → [SET]

- The base unit will not ring for outside calls.
The base unit will ring at the low level for intercom calls.
- To turn the ringer back ON, press [+].

Ringtone

- You can select the desired base unit ringtone for outside calls (feature #17 on page 51).

Handset receiver volume

While using the receiver, press [+] or [-].

Speaker volume

While using the speakerphone, press [+] or [-].

2.7 Date and time

The date and time can be set using either the cordless handset or the base unit.

- The other party's fax machine will print the date and time on the top of each page you send according to your unit's date and time setting.

2.7.1 With the cordless handset

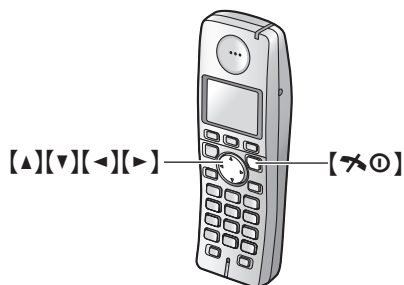

- Press **OK**.
- Select **☰** by pressing **[▲]**, **[▼]**, **[◀]**, or **[▶]**. → **OK**
- Press **[▲]** or **[▼]** to select "Time Settings". → **OK**
- Press **[▲]** or **[▼]** to select "Set Date & Time". → **OK**
- Enter the current date/month/year/hour/minute by selecting 2 digits for each.
Example: 10 August, 2006 10:15 PM (12 hour clock format)
 - Press **[1][0] [0][8] [0][6] [1][0] [1][5]**.

Date	:10-08-06
Time	:10:15
	*=12/24
 - Press **[✳]** repeatedly to select "PM".
- OK**
- Press **[✳][⊙]** to exit.

To correct a mistake

Press **[◀]** or **[▶]** to move the cursor to the incorrect number, and make the correction.

2.7.2 With the base unit

Important:

- If **☰** is displayed on the base unit, either the date and time has not been set or the setting has been lost (due to a power failure, etc.). Set the date and time by pressing **[SET]**, then follow step 2 and 3.

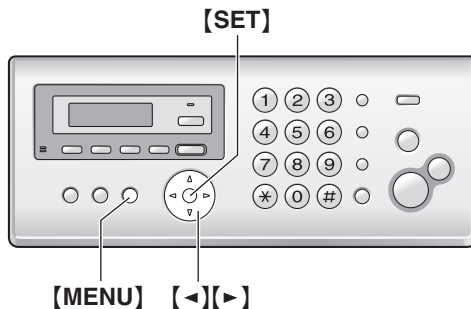

- [MENU] → [☰][0][1] → [SET]**

D:01/M:01/Y:06
TIME: 00:00
- Enter the current date/month/year/hour/minute by selecting 2 digits for each.
Example: 10 August, 2006 10:15 PM (12 hour clock format)
 - Press **[1][0] [0][8] [0][6] [1][0] [1][5]**.

D:10/M:08/Y:06
TIME: 10:15
 - Press **[✳]** repeatedly to select "PM".
- [SET]**
- Press **[MENU]** to exit.

To correct a mistake

Press **[◀]** or **[▶]** to move the cursor to the incorrect number, and make the correction.

If you have subscribed to a Caller ID service

The date and time will be automatically set according to the received caller information.

- If the time has not previously been set, Caller ID will not adjust the clock.

2.8 Your logo

You can program your logo (name, company name, etc.) so that it appears on the top of each page sent.

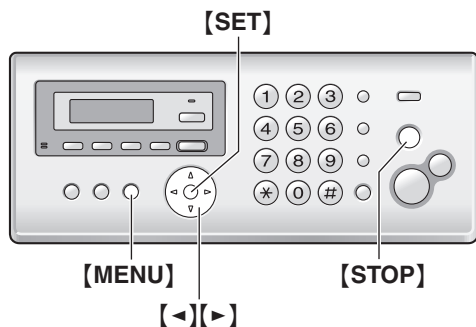

- 1 **[MENU]** → **[*][0][2]** → **[SET]**

LOGO=	[# :ABC]
-------	----------

- 2 Enter your logo, up to 30 characters (see page 62 for character entry). → **[SET]**
- 3 Press **[MENU]** to exit.

To correct a mistake

Press **[<-]** or **[>-]** to move the cursor to the incorrect character, and make the correction.

- To erase all of the characters, press and hold **[STOP]**.

2.9 Your fax number

You can program your fax number so that it appears on the top of each page sent.

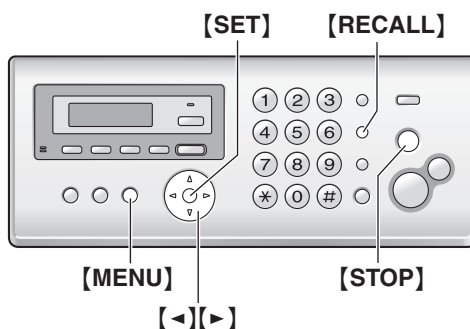

- 1 **[MENU]** → **[*][0][3]** → **[SET]**

NO. =

- 2 Enter your fax number, up to 20 digits.
 - To enter a "+", press **[*]**.
 - To enter a space, press **[*]**.
 - To enter a hyphen, press **[RECALL]**.
 - To erase a number, press **[STOP]**.

- 3 **[SET]**

- 4 Press **[MENU]** to exit.

To correct a mistake

Press **[<-]** or **[>-]** to move the cursor to the incorrect number, and make the correction.

- To erase all of the numbers, press and hold **[STOP]**.

3.1 Making phone calls

3.1.1 With the cordless handset

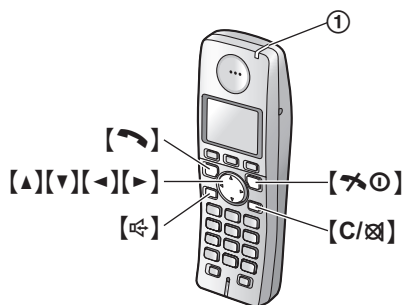

- 1 Lift the cordless handset and press [📞].
 - To make hands-free phone calls, press [📞].
- 2 Dial the telephone number.
- 3 To hang up, press [📞] or place the cordless handset on the charger.

Note:

- While talking using [📞], you can switch to a hands-free phone conversation by pressing [📞]. To switch back, press [📞].
- You can also dial by performing step 2 before step 1.

To mute your conversation

When the call is muted, you will be able to hear the other party but the other party will not be able to hear you.

Press [C/📞].

- To release the mute, press [C/📞].

Voice enhancer feature

You can change the tone quality of the receiver while you are on a call.

1. Press [📞] during a call.
2. Select "Voice Enhancer". → **OK**
3. "High Tone" or "Low Tone". → **OK**
 - 📞 is displayed.

To redial the last number dialed from the cordless handset

Press [📞] or [📞]. → **📞**

- If [📞] is pressed and the other party's line is engaged, the unit will automatically redial 2 or more times. While the cordless handset is waiting to redial, the ringer indicator (1) will flash.

To redial using the redial list (Memory redial)

The last 10 phone numbers dialed from the cordless handset are stored in the redial list.

1. **📞**
2. Press [▲] or [▼] to select the desired number.

3. [📞] or [📞]

To edit a number in the redial list before calling it

1. **📞**
2. Press [▲] or [▼] repeatedly to select the desired number. → **📞**
3. Press [▲] or [▼] repeatedly to select "Edit and Call". → **OK**
4. Press [◀] or [▶] to move the cursor then edit the number.
 - Place the cursor on the number you wish to erase, then press [C/📞].
 - Place the cursor to the right of where you want to insert a number, then press the appropriate dial key.
5. [📞], [📞] or **OK**

To erase numbers in the redial list

1. **📞**
2. Press [▲] or [▼] repeatedly to select the desired number. → **📞**
3. Press [▲] or [▼] repeatedly to select "Erase". → **OK**
 - If you want to erase all numbers in the list, select "Erase All", then press **OK**.
4. Press [▲] or [▼] repeatedly to select "Yes" → **OK** → [📞]

To store a number from the redial list into the cordless handset phonebook

1. **📞**
2. Press [▲] or [▼] repeatedly to select the desired number. → **📞**
3. Press [▲] or [▼] repeatedly to select "Add Phonebook". → **OK**
4. Enter a name up to 16 characters (see page 62 for character entry). → **OK**
5. Edit the phone number if necessary. → **OK**
6. Select the desired category (page 25). → **OK**
7. "Save" → **OK** → [📞]

Key lock

The cordless handset can be locked so that no calls or settings can be made. Incoming calls can be answered, but all other functions are disabled while key lock is ON. To turn key lock ON, press [📞] for about 2 seconds.

- **📞** is displayed.
- To turn key lock OFF, press **📞** for about 2 seconds.

3.1.2 With the base unit



- 1 Lift the handset or press **[SP-PHONE]**.
- 2 Dial the telephone number.
- 3 To hang up, replace the handset or press **[SP-PHONE]**.

Note:

- You can also dial by performing step 2 before step 1.

To redial the last number dialed from the base unit

Lift the handset or press **[SP-PHONE]**. → **[REDIAL]**

- If **[SP-PHONE]** is pressed and the line is engaged, the unit will automatically redial 2 or more times.

3.2 Answering phone calls

3.2.1 With the cordless handset

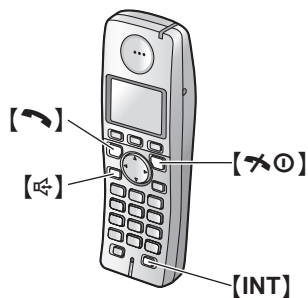

- 1 Lift the cordless handset and press **[hook]** or **[hook]**.
 - You can also answer a call by pressing any dial key from **[0]** to **[9]**, **[*]**, **[#]** or **[INT]** (**Any key talk feature**).
- 2 To hang up, press **[hook]** or place the cordless handset on the charger.

Auto talk feature (Cordless handset)

This feature allows you to answer a call by simply lifting the cordless handset off the charger (page 56).

3.2.2 With the base unit

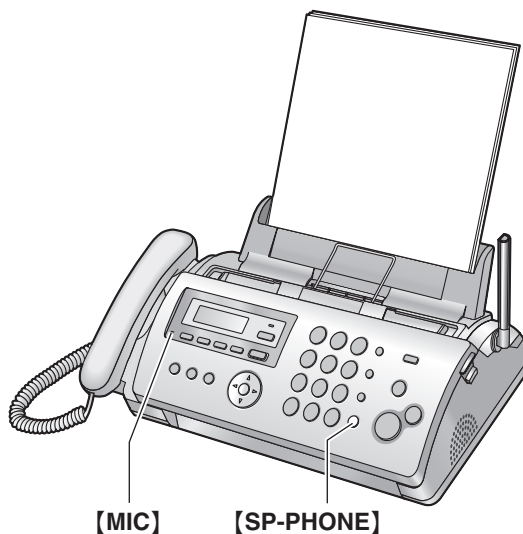

- 1 Lift the handset or press **[SP-PHONE]** and talk into **[MIC]**.
- 2 To hang up, replace the handset or press **[SP-PHONE]**.

3.3 Using the recall feature

[RECALL] (base unit) / **[R]** (cordless handset) is used to access optional telephone services such as call waiting. Contact your telephone company business office for details.

Call waiting

When a call waiting tone is heard during a conversation, **place the existing call on hold and answer the second call by pressing [RECALL] / [R].**

- Each time you press **[RECALL] / [R]**, you can switch between the first and second call.
- Incoming calls cannot be dropped by the person who has received the call.

Note:

- If your unit is connected to a PBX, pressing **[RECALL] / [R]** allows you to access some features of your host PBX such as transferring an extension call.
- You can change the recall/flash time (feature #72 on page 55).

3.4 Recording a telephone conversation (Cordless handset only)

Important:

- **Before recording a conversation, you should inform the other party that the conversation will be recorded.**

- 1 Press **[RECALL]** during an outside call.
- 2 **"Record Call" → OK**
 - A beep is heard and recording starts.
 - A beep sounds every 15 seconds and can be heard by the other party.
- 3 To stop recording, press **[STOP]**.

Note:

- To listen to the recorded conversation, see page 46.

3.5 Night mode

Night mode allows you to select a block of time during which the cordless handset will not ring for outside calls. This feature is useful for times when you do not want to be disturbed, for example, while sleeping.

Using the cordless handset phonebook's category feature (page 25), you can also select categories of callers whose calls will override night mode and ring the cordless handset (Caller ID subscribers only). Set the date and time beforehand (page 20).

Important:

- **We recommend you to use this feature in TEL mode. Using this feature in other modes**

(TAM/FAX or FAX ONLY), the ring delay setting may not function properly.

Note:

- Night mode can be set for the base unit and the cordless handset separately.

3.5.1 Cordless handset

To set the start and end time for night mode

1. **[RECALL] → [R] → OK**
2. **"Ringer Setup" → OK**
3. **"Night Mode" → OK**
4. **"Start/End" → OK**
5. Enter the desired hour and minute you wish to start this feature.
 - If you use 12-hour time entry, select **"AM"** or **"PM"** by pressing **[*]** repeatedly before entering the time.
6. Enter the desired hour and minute you wish to end this feature.
 - If you use 12-hour time entry, select **"AM"** or **"PM"** by pressing **[*]** repeatedly before entering the time.
7. **OK → [NEXT]**

To turn night mode ON/OFF

1. **[RECALL] → [R] → OK**
2. **"Ringer Setup" → OK**
3. **"Night Mode" → OK**
4. **"On/Off" → OK**
5. **"On" or "Off" (default) → OK → [NEXT]**
 - When the night mode is set,  is displayed.

To set the ring delay for night mode

This setting allows the cordless handset to ring during night mode if the caller waits long enough. After the selected amount of time passes, the cordless handset will ring. If you select **"No Ringing"**, the cordless handset will not ring during night mode.

1. **[RECALL] → [R] → OK**
2. **"Ringer Setup" → OK**
3. **"Night Mode" → OK**
4. **"Ring Delay" → OK**
5. Select the desired setting. **→ OK → [NEXT]**

To select categories to bypass night mode

1. **[RECALL] → [R] → OK**
2. **"Ringer Setup" → OK**
3. **"Night Mode" → OK**
4. **"Select Category" → OK**
5. Press the desired category numbers. **→ OK**
 - The selected category number will flash.

- To cancel a selected category number, press the number again. The number will stop flashing.

6. [✳️] [0]

3.5.2 Base unit

To set the start and end time for night mode

1. [MENU] → [✳️][3][5] → [SET] → [1] → [SET]
2. Enter the desired hour and minute you wish to start this feature.
 - If you use 12-hour time entry, select “AM” or “PM” by pressing [✳️] repeatedly before entering the time.
3. Enter the desired hour and minute you wish to end this feature.
 - If you use 12-hour time entry, select “AM” or “PM” by pressing [✳️] repeatedly before entering the time.
4. [SET] → [MENU]

To set night mode ON/OFF

1. [MENU] → [✳️][3][5] → [SET] → [2] → [SET]
2. Press [0] or [1] to select the desired setting.
 - [0] “OFF” (default)
 - [1] “ON”
3. [SET] → [MENU].

Note:

- When the night mode is set, “[N]” is displayed.

To set the ring delay for night mode

This setting allows the base unit to ring during night mode if the caller waits long enough. After the selected delay time has passed, the base unit will ring. If you select “NO RINGING”, the base unit will not ring during night mode.

1. [MENU] → [✳️][3][5] → [SET] → [3] → [SET]
2. Press [0] to [4] to select the desired setting.
 - [0] “NO RINGING”: the base unit will not ring.
 - [1] “30sec.”: 30 seconds
 - [2] “60sec.” (default): 60 seconds
 - [3] “90sec.”: 90 seconds
 - [4] “120sec.”: 120 seconds
3. [SET] → [MENU]

3.6 Cordless handset phonebook

You can store 200 items to the cordless handset phonebook.

When the system has additional cordless handsets (page 59), each cordless handset can have its own phonebook.

- The base unit has its own individual phonebook (page 26).
- You can copy phonebook items between the base unit and the cordless handset, or between two cordless handsets (page 61).

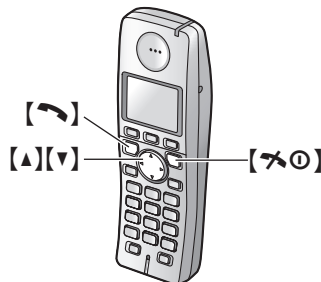

3.6.1 Storing phonebook items

1. [Phonebook icon] → [Keypad icon]
2. “New Entry” → OK
3. Enter the name, up to 16 characters (see page 62 for character entry). → OK
4. Enter the telephone number, up to 24 digits. → OK
5. Select the desired category. → OK
6. “Save” → OK
 - To program other items, repeat steps 3 to 6.
7. [✳️] [0]

3.6.2 Categories

Categories can help you find items in the cordless handset phonebook quickly and easily. When adding an item to the cordless handset phonebook you can assign it to the desired category. You can change the names of categories assigned for cordless handset phonebook items (“Friends”, “Family”, etc.) and then search for cordless handset phonebook items by category. Additional category features are available for Caller ID subscribers (page 29).



To change category names

1. [Phonebook icon] → [Keypad icon]
2. “Category” → OK
3. Select the desired category. → OK
4. “Category Name” → OK
5. Edit the name, up to 10 characters (see page 62 for character entry). → OK → [✳️] [0]



3.6.3 Making a phone call using the phonebook

- 1 
- 2 Press [**▲**] or [**▼**] repeatedly to display the desired item. → [**↶**]

To search for a name by initial

1. 
2. Press the dial key ([**0**] to [**9**]) which contains the character you are searching for (page 62).
 - Press the same dial key repeatedly to display the first item corresponding to each letter located on that dial key.
 - If there is no item corresponding to the letter you selected, the next item will be displayed.
 - To change the character entry mode:
 → “Index Search” → **OK** → Select the character entry mode. → **OK**
3. Press [**▲**] or [**▼**] repeatedly to scroll through the phonebook if necessary.

To search for a name by category

1.  → 
2. “Category Search” → **OK**
3. Select the category you want to search. → **OK**
 - If you select “All”, the unit will end the category search.
4. Press [**▲**] or [**▼**] repeatedly to scroll through the phonebook if necessary.

3.6.4 Editing a stored item

Changing a name, phone number, category



1. Find the desired item (page 26). → 
2. “Edit” → **OK**
3. Edit the name if necessary. For further details, see the storing procedure on page 25. → **OK**
4. Edit the phone number if necessary. For further details, see the storing procedure on page 25. → **OK**
5. Select the desired category. → **OK**
6. “Save” → **OK** → [**↶**]

3.6.5 Erasing a stored item

To erase a specific item

1. Find the desired item (page 26). → 
2. “Erase” → **OK**
3. “Yes” → **OK** → [**↶**]

To erase all items

1.  → 

2. “Erase All” → **OK**
3. “Yes” → **OK**
4. “Yes” → **OK** → [**↶**]

3.7 Chain dial (Cordless handset only)

This feature allows you to dial phone numbers in the cordless handset phonebook while you are on a call. This feature can be used, for example, to dial a calling card access number or bank account PIN that you have stored in the cordless handset phonebook, without having to dial manually.

- 1 While on a call, press .
- 2 Press [**▲**] or [**▼**] repeatedly to select the desired item.
 - To search by first character (index search), see page 26. To search by category, see page 26.
- 3 Press **OK** to dial the number.

3.8 Base unit phonebook

You can store 100 items to the base unit phonebook.

- The cordless handset has its own individual phonebook (page 25).
- You can copy phonebook items between the base unit and the cordless handset (page 61).

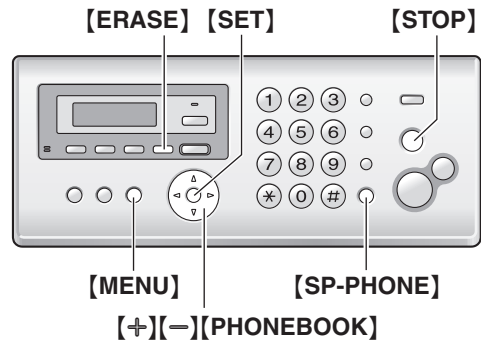

3.8.1 Storing phonebook items

- 1 Press [**MENU**] repeatedly to display “PHONEBOOK SET”. → [*****]
- 2 Enter the name, up to 16 characters (see page 62 for character entry). → [**SET**]
- 3 Enter the telephone number, up to 24 digits. → [**SET**]
 - To program other items, repeat steps 2 to 3.
- 4 [**MENU**]

3.8.2 Making a phone call using the phonebook

- 1 [**PHONEBOOK**]

- 2 Press **[+]** or **[-]** repeatedly to display the desired item.
- 3 Lift the handset or press **[SP-PHONE]**.

To search for a name by initial

- 1 **[PHONEBOOK]**
- 2 Press **[+]** or **[-]** to initiate the phonebook.
- 3 Press the dial key (**[0]** to **[9]**) which contains the character you are searching for (page 62).
 - Press the same dial key repeatedly to display the first item corresponding to each letter located on that dial key.
 - If there is no item corresponding to the letter you selected, press another dial key.
- 4 Press **[+]** or **[-]** repeatedly to scroll through the phonebook if necessary.

3.8.3 Editing a stored item

- 1 **[PHONEBOOK]**
- 2 Press **[+]** or **[-]** repeatedly to display the desired item. → **[MENU]** → **[*]**
- 3 Edit the name if necessary. For further details, see the storing procedure on page 26. → **[SET]**
- 4 Edit the telephone number if necessary. For further details, see the storing procedure on page 26. → **[SET]**

3.8.4 Erasing a stored item

- 1 **[PHONEBOOK]**
- 2 Press **[+]** or **[-]** repeatedly to display the desired item. → **[MENU]** → **[†]**
 - To cancel erasing, press **[STOP]**.
- 3 **[SET]**

3.8.5 Erasing all items

- 1 **[PHONEBOOK]** → **[ERASE]**
- 2 Press **[+]** or **[-]** repeatedly to select **“YES”**. → **[SET]**
 - To cancel erasing, press **[STOP]**.
- 3 **[SET]**

3.9 One touch dial

3.9.1 Cordless handset

Cordless handset dial keys **[1]** to **[9]** can each be used as a one touch dial key, allowing you to dial a number from the cordless handset's phonebook by simply pressing a dial key.

To assign an item to a one touch dial key

1. Find the desired item (page 26). → **[☰]**

2. **“One Touch Dial”** → **OK**
3. Press **[▲]** or **[▼]** repeatedly to select a desired dial key. → **OK**
 - When the dial key is already used as a one touch dial key, **“*”** is displayed next to the dial key number. If you select this dial key, you can overwrite the previous assignment.
4. **“Save”** → **OK** → **[↶⊙]**

To make a call using a one touch dial key

1. Press and hold the desired one touch dial key (**[1]** to **[9]**).
 - You can view other one touch dial assignments by pressing **[▲]** or **[▼]**.
2. **[↶]** or **[☎]**

To erase a one touch dial assignment

1. Press and hold the desired one touch dial key (**[1]** to **[9]**). → **[☰]**
2. **“Erase”** → **OK**
3. **“Yes”** → **OK** → **[↶⊙]**

Note:

- The corresponding handset phonebook item will not be erased.

3.9.2 Base unit

Base unit dial keys **[1]** to **[9]** can each be used as a one touch dial key, allowing you to dial a number from the base unit's phonebook by simply pressing a dial key.

To assign an item to a one touch dial key

1. **[PHONEBOOK]**
2. Press **[+]** or **[-]** repeatedly to display the desired item. → **[MENU]** → **[0]**
3. Press **[+]** or **[-]** repeatedly to select a desired dial key.
 - When the dial key is already used as a one touch dial key, **✓** is displayed next to the dial key number. If you select this dial key, you can overwrite the previous assignment.
4. **[SET]** → **[SET]**
 - To program other items, repeat steps 2 to 4.
5. **[STOP]**

To make a call using a one touch dial key

1. Press and hold the desired one touch dial key (**[1]** to **[9]**).
 - You can view other one touch dial assignments by pressing **[+]** or **[-]**.
2. Lift the handset or press **[SP-PHONE]**.

To erase a one touch dial assignment

1. Press and hold the desired one touch dial key (**[1]** to **[9]**). → **[ERASE]**

3. Telephone

- To cancel erasing, press **[STOP]**.

2. **[SET]**

Note:

- The corresponding base unit phonebook item will not be erased.

3.10 Caller ID service

This unit is compatible with the Caller ID service offered by your local telephone company. To use this unit's Caller ID features, you must subscribe to a Caller ID service.

Important:

- **This unit will only display the caller's telephone number and name.**
- **This unit will not support future additional telephone services.**
- **Depending on the service of the local telephone company, the date/time of the call or the caller's name may not be displayed.**

Make sure the following ring count is set to 2 or more rings beforehand.

- TAM ring count (page 48, feature #06 on page 50)
- FAX ring count (feature #06 on page 50)
- The name display service may not be available in some areas. For further information, please contact your telephone company.

3.10.1 How Caller ID is displayed

The calling party's name or telephone number will be displayed after the 1st ring. You have the option of whether or not to answer the call.

The unit will automatically store caller information (name, telephone number, date and time of the call) from the 50 most recent callers.

It is possible to view caller information one at a time on the display (page 29) or print the entire Caller ID list (page 78).

- When caller information is received and it matches a telephone number stored in the unit's phonebook:
 - The stored name will be displayed and logged.
 - The cordless handset will use the ringtone assigned to the caller's category.
- If the unit is connected to a PBX (Private Branch Exchange) system, caller information may not be received properly. Consult your PBX supplier.
- If the unit cannot receive caller information, the following will be displayed:
 - “**OUT OF AREA**”: The caller dialed from an area which does not provide Caller ID service.
 - “**PRIVATE CALLER**”: The caller requested not to send caller information.
 - “**LONG DISTANCE**”: The caller made a long distance call.

Note:

- Although Telstra and Optus do not currently send caller name information, the caller's name will be displayed as stored in the directory, when a call from that caller is received.
- The area code will need to be stored with the 8-digit telephone number.

Missed calls

If a call is not answered, the unit treats the call as a missed call. The number of missed calls are shown on the display (the cordless handset also shows →). This lets you know if you should view the caller list to see who called while you were out.

To confirm caller information by printing the Caller ID list (Base unit only)

- To print manually, see page 78.
- To print automatically after every 50 new calls, activate feature #26 (page 52).

Call Waiting Caller ID feature

If you subscribe to both Caller ID and Call Waiting services, when a second call is received during a conversation, you will hear a call-waiting tone and the display will show the second caller's information. Press [R] on the cordless handset or [RECALL] on the base unit to answer the second call.

- To return to the first caller, press [R] on the cordless handset or [RECALL] on the base unit again.

Note:

- The second caller's information will not be displayed when:
 - the first call is placed on hold,
 - the answering machine is recording an incoming message,
 - an extension telephone on the same line is in use, or
 - you are sending or receiving a fax document.

3.10.2 Category features for cordless handset phonebook

Categories can help you identify who is calling by using different ringtones and display colours for different categories of callers. When adding an item to the cordless handset phonebook you can assign it to the desired category (page 25). When a call is received from a caller assigned to a category, the category's display colour and ringtone you selected are used.

Changing category ringtones

If you select "Ext. Ringtone", the unit will use the external ringtone you set on page 56 when calls from this category are received. The default setting is "Ext. Ringtone".

1. [M] → [M]
2. "Category" → [OK]
3. Select a category. → [OK]
4. Select the current setting of the category ringtone. → [OK]
5. Select the desired ringtone. → [OK] → [↶⊙]

Changing category display colours

If you select "Display Colour", the unit will use the display colour you set on page 56 when calls from this category are received. The default setting is "Display Colour".

1. [M] → [M]
2. "Category" → [OK]
3. Select a category. → [OK]
4. Select the current setting of the category colour. → [OK]
5. Select the desired colour. → [OK] → [↶⊙]

3.11 Viewing and calling back

Important:

- Calling back will not be possible if the caller information does not include a telephone number.
- If the area code of the received telephone number is the same as yours, the area code may need to be deleted before calling back. This may only apply to some areas. To edit the number, see page 30.

3.11.1 With the cordless handset

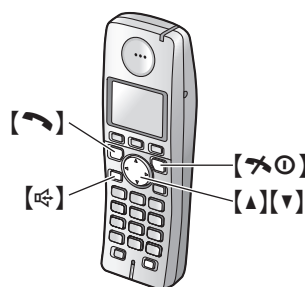

1. [M] → [M] → [OK]
2. Press [↵] to search from the recently received caller information.
 - If you press [▲], the display order will be reversed.
 - A ✓ on the display means the item has already been viewed or answered.
3. Press [↶] or [↶] to return the call.

To stop viewing

Press [↶⊙].

3. Telephone

3.11.2 With the base unit

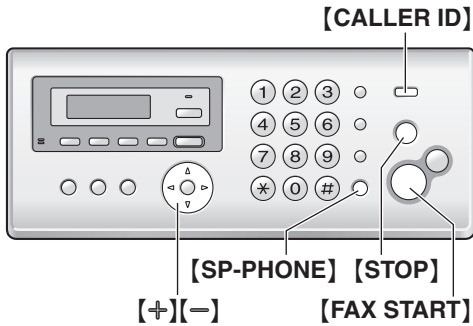

- 1 **[CALLER ID]**
- 2 Press **[−]** to search from the recently received caller information.
 - If you press **[+]**, the display order will be reversed.
 - A ✓ on the display means the item has already been viewed or answered.
- 3 Lift the handset or press **[SP-PHONE]** to return the call.
 - To send a fax, insert the document FACE DOWN and press **[FAX START]**.

To change the way caller information is displayed

Press **[CALLER ID]** repeatedly after step 2.

Example:

SAM LEE 11:20AM Jul. 20✓
↑
3456789012 11:20AM Jul. 20✓

3.11.3 Symbols and operations for caller information

What “✓” means

“✓” on the display means the call has already been viewed or answered.

To stop viewing

Press **[STOP]**.

Note:

- Telstra and Optus do not currently send caller name information.

3.12 Editing a caller’s telephone number before calling back

3.12.1 With the cordless handset

- 1 **[MENU]** → **[↩]** → **[OK]**

- 2 Press **[▲]** or **[▼]** repeatedly to display the desired item.
- 3 **[EDIT]** → “Edit and Call” → **[OK]**
- 4 Edit the number.
 - Press dial key (**[0]** to **[9]**) to add, **[C/✕]** to delete.
- 5 **[↩]**, **[↶]** or **[OK]**

3.12.2 With the base unit

- 1 Press **[CALLER ID]**.
- 2 Press **[+]** or **[−]** repeatedly to display the desired item.
- 3 Press **[CALLER ID]** repeatedly to display the telephone number.
- 4 Edit the number.
 - Press dial key (**[0]** to **[9]**) to add, **[STOP]** to delete.
- 5 Lift the handset or press **[SP-PHONE]** to call back the edited number.
 - The unit will start dialling automatically.
 - To send a fax, insert the document FACE DOWN and press **[FAX START]**.

Note:

- Telstra and Optus do not currently send caller name information.

3.13 Erasing caller information

3.13.1 With the cordless handset

- 1 **[MENU]** → **[↩]** → **[OK]**
- 2 Press **[▲]** or **[▼]** repeatedly to display the desired item. → **[MENU]**
- 3 “Erase” → **[OK]**
 - To erase all items, select “Erase All”. → **[OK]**
- 4 “Yes” → **[OK]** → **[↶]**

3.13.2 With the base unit

To erase all caller information

- 1 Press **[MENU]** repeatedly to display “CALLER SETUP”. → **[SET]**
 - “CALL LIST ERASE” will be displayed.
- 2 **[SET]**
 - To cancel erasing, press **[STOP]**, then **[MENU]**.
- 3 **[SET]** → **[STOP]**

To erase specific caller information

- 1 **[CALLER ID]**
- 2 Press **[+]** or **[−]** repeatedly to display the desired item. → **[ERASE]** → **[STOP]**

Note:



- Telstra and Optus do not currently send caller name information.

3.14 Storing caller information into the phonebook

Important:

- This feature is not available if the caller information does not include a telephone number.

3.14.1 Into the cordless handset

- 1  →  → **OK**
- 2 Press [**▲**] or [**▼**] repeatedly to display the desired item. → 
- 3 “Add Phonebook” → **OK**
- 4 If a name is required, enter the name, up to 16 characters (see page 62 for character entry). → **OK**
- 5 Enter the telephone number, up to 24 digits. → **OK**
- 6 Select the desired category. → **OK**
- 7 “Save” → **OK** → [**↶**]

3.14.2 Into the base unit

- 1 [**CALLER ID**]
- 2 Press [**+**] or [**-**] repeatedly to display the desired item. → [**MENU**]
- 3 If a name is required, enter up to 16 characters for the name (see page 62 for character entry). → [**SET**] → [**SET**]

Note:

- Telstra and Optus do not currently send caller name information.

3.15 Using SMS (Short Message Service)

SMS allows you to send and receive text messages between other fixed-line and mobile phones that support compatible SMS networks and features.

Important:

- To use SMS features, you must:
 - subscribe to the Caller ID and/or appropriate service
 - confirm SMS is turned ON
 - confirm the correct message centre numbers are stored

Consult your service provider/telephone company for details and availability.

Using the public mailbox and private mailboxes

SMS messages can be sent and received using the public mailbox or any one of the 6 private mailboxes. The public mailbox can be accessed freely. Private mailboxes are password protected to ensure privacy.



Important:

- To use the public mailbox, you must:
 - register the public mailbox with BT Text (page 32)
- To send or receive a message using a private mailbox, you must:
 - first create the private mailbox by storing its name and password (page 33)
 - register each private mailbox with BT Text (page 32)

Note:

- A total of 47 messages (at 160 characters/message) in all mailboxes added together can be saved. Total number may be more than 47 if length of messages is less than 160 characters/message.
- SMS messages are displayed on the cordless handset. The base unit displays the following when sending and receiving SMS messages:
 - “**TRANSFERRING MESSAGE**”: Displayed when a message is being sent.
 - “**RECEIVING NEW SMS**”: Displayed when a message is being received.
- If the unit is connected to a PBX system, you may not be able to use SMS features.



3.16 Turning SMS ON/OFF

- 1  →  → **OK**
- 2 “Public” → **OK**
- 3 “Settings” → **OK**
- 4 “SMS On/Off” → **OK**
- 5 “On” or “Off” → **OK** → [**↶**]

3.17 Changing SMS message centre numbers

SMS message centre telephone numbers must be stored in order to send and receive SMS messages. The message centre numbers (used for SMS services provided by BT Text) are preprogrammed in this unit. You can change them if necessary.

- Consult your service provider/telephone company for more information.

- 1  →  → **OK**
- 2 “Public” → **OK**
- 3 “Settings” → **OK**
- 4 “Message Centre1” or “Message Centre2” → **OK**
- 5 Edit the number as necessary. → **OK**
- 6 “Save” → **OK** → 

Note:

- If your phone is connected to a PBX, you need to add the PBX line access number and a dialling pause to the beginning of the Message Centre 1 phone number.



3.18 Registering mailboxes

Each SMS mailbox you wish to use must be registered with BT Text. There are two ways you can register a mailbox:

- Send an SMS message to another person.
- Send the text message ‘REGISTER’ to destination number 00000.

3.19 Sending a message

3.19.1 Writing and sending a new message

- 1  →  → **OK**
- 2 **To access the public mailbox**
“Public” → **OK**
To access a private mailbox
Select the desired mailbox. → **OK** → Enter its password.
- 3 “Create” → **OK**
 - If “▲Use Last Text?” is displayed, you can use the text from the last message you created by pressing **▲**.
- 4 Enter the message (page 62). → **OK**
- 5 Enter the destination phone number, up to 20 digits. → **OK**
 - Using the cordless handset phonebook:
 → Select the cordless handset phonebook item. → **OK** 2 times
 - Using the Caller ID list:

Press **▲** or **▼** to select the party. → **OK** 2 times

- Using the redial list:
Press  repeatedly to select the phone number. → **OK** 2 times
- If you wish to send the message to the other party’s mailbox, enter the other party’s mailbox number after the destination phone number.
Example: The other party’s phone number is 123456 and their mailbox number is 1.
Enter 1234561.



- 6 To save the message, select “Yes”. → **OK**

- 7 To send the message, press **OK**.
 - To cancel sending, press .

Note:

- This unit supports SMS messages of up to 612 characters, however, the maximum number of characters you can send or receive may be limited by your SMS service provider/telephone company. Consult your SMS service provider/telephone company for details.
- If your message contains over 160 characters, the message is a long message and  is displayed. Your service provider/telephone company may treat long messages differently from other messages. Consult your service provider/telephone company for details.
- If your phone is connected to a PBX, store the PBX line access number (page 34).

3.19.2 Sending a saved message

- 1  →  → **OK**
- 2 **To access the public mailbox**
“Public” → **OK**
To access a private mailbox
Select the desired mailbox. → **OK** → Enter its password.
- 3 “Send List” → **OK**
- 4 To read a saved message, press **▲** or **▼** repeatedly to select the message. → **OK**
- 5 To send the message, press . → “Send” → **OK**
- 6 Press and hold **[C/✕]** to erase all numbers, then continue from step 5, “3.19.1 Writing and sending a new message”, page 32.

3.19.3 Editing and sending a saved message

- 1  →  → **OK**
- 2 **To access the public mailbox**
“Public” → **OK**
To access a private mailbox
Select the desired mailbox. → **OK** → Enter its password.

- 3 “Send List” → **OK**
- 4 Press [**▲**] or [**▼**] repeatedly to select the message.
→ **OK**
- 5 **☰** → “Edit Message” → **OK** → Continue from step 4, “3.19.1 Writing and sending a new message”, page 32.

3.19.4 Erasing saved messages

- 1 **☰** → **✉** → **OK**
- 2 **To access the public mailbox**
“Public” → **OK**
To access a private mailbox
Select the desired mailbox. → **OK** → Enter its password.
- 3 “Send List” → **OK**
- 4 Press [**▲**] or [**▼**] repeatedly to select the message.
→ **OK**
- 5 **☰** → “Erase” → **OK**
 - To erase all messages in the selected mailbox, select “Erase All”. → **OK**
- 6 “Yes” → **OK** → [**↶**]

3.20 Receiving a message

When an SMS message is received:

- a tone is heard (if the cordless handset ringer is turned ON).
- “Receiving SMS Message” is displayed.
- **✉** is displayed.
- the message indicator on the cordless handset flashes if the message alert feature (page 56) has been turned ON.
- the total number of new (unread) SMS messages is displayed next to **✉**.

3.20.1 Reading a received message

- 1 **☰** → **✉** → **OK**
- 2 **To access the public mailbox**
“Public” → **OK**
To access a private mailbox
Select the desired mailbox. → **OK** → Enter its password.
 - If a mailbox contains new (unread) SMS messages, “*” is displayed next to the total number of messages for that mailbox.
- 3 “Receive List” → **OK**
- 4 Press [**▲**] or [**▼**] repeatedly to select a message.
 - Messages which have already been read are indicated by a “✓”, even if they were read using another cordless handset.
 - To erase a message, press **✕**. → “Yes” → **OK**
- 5 Press **OK** to read the message content.

Note:

- To call the message sender, press [**↶**] or [**☎**].

3.20.2 Replying to a message

- 1 While reading a received message, press **☰**.
- 2 “Reply” → **OK**
- 3 Enter a message (page 62). → **OK**
- 4 Edit the destination phone number and/or press **OK**, then continue from step 6, “3.19.1 Writing and sending a new message”, page 32.

Editing/forwarding a message

1. While reading a received message, press **☰**.
2. “Edit Message” → **OK** → Continue from step 4, “3.19.1 Writing and sending a new message”, page 32.

3.20.3 Erasing received messages

- 1 While reading a received message, press **☰**.
- 2 “Erase” → **OK**
 - To erase all messages in the selected mailbox, select “Erase All”. → **OK**
- 3 “Yes” → **OK** → [**↶**]

3.20.4 Storing the sender’s number in the cordless handset phonebook

- 1 While reading a received message, press **☰**.
- 2 “Add Phonebook” → **OK**
- 3 Continue from step 3, “3.6.1 Storing phonebook items”, page 25.

3.20.5 Editing the sender’s number before calling back

- 1 While reading a received message, press **☰**.
- 2 “Edit and Call” → **OK**
- 3 Edit the number. → [**↶**], [**☎**] or **OK**

3.21 Guide to SMS settings

3.21.1 Creating private mailboxes

Private mailboxes can be used for sending and receiving SMS messages. Each private mailbox is password protected.

- 1 **☰** → **✉** → **OK**
- 2 “Public” → **OK**
- 3 “Settings” → **OK**
- 4 “Private Mailbox” → **OK**

3. Telephone

- 5 Select the desired new mailbox number (“Mailbox1” to “Mailbox6”). → **OK**
- 6 Enter a name for the mailbox up to 5 characters (see page 62 for character entry). → **OK**
- 7 Enter a 4-digit password for the mailbox. → **OK**
- 8 “Save” → **OK** → [**↶** **⊙**]

Note:

- To receive SMS messages using a mailbox, inform others of your mailbox number.
- If you forget the password assigned to a mailbox, consult your nearest Panasonic service centre.

3.21.2 Changing private mailbox settings

You can change the password or name of the private mailbox and erase the mailbox.

- 1 **[☰]** → **[✉]** → **OK**
- 2 “Public” → **OK**
- 3 “Settings” → **OK**
- 4 “Private Mailbox” → **OK**
- 5 Select the desired mailbox name. → **OK** 2 times
- 6 Enter the mailbox’s 4-digit password.
- 7 Edit the mailbox name, up to 5 characters (see page 62 for character entry). → **OK**
 - To erase the mailbox, press and hold **[C/✕]**. → **OK** → “Yes” → **OK** → [**↶** **⊙**]
- 8 Enter a 4-digit password for the mailbox. → **OK**
- 9 “Save” → **OK** → [**↶** **⊙**]

Note:

- If you erase a mailbox, its messages will also be erased.

3.21.3 Storing the PBX line access number (for PBX users only)

Store your PBX line access number up to 4 digits so that SMS messages are sent properly. When sending SMS messages to items in the cordless handset phonebook or redial list, the PBX line access number will be deleted.

- 1 **[☰]** → **[✉]** → **OK**
- 2 “Public” → **OK**
- 3 “Settings” → **OK**
- 4 “PBX Access No.” → **OK**
- 5 “On” → **OK**
- 6 Enter your PBX line access code and a dialling pause, if necessary. → **OK**
- 7 “Save” → **OK** → [**↶** **⊙**]

4.1 Sending a fax manually

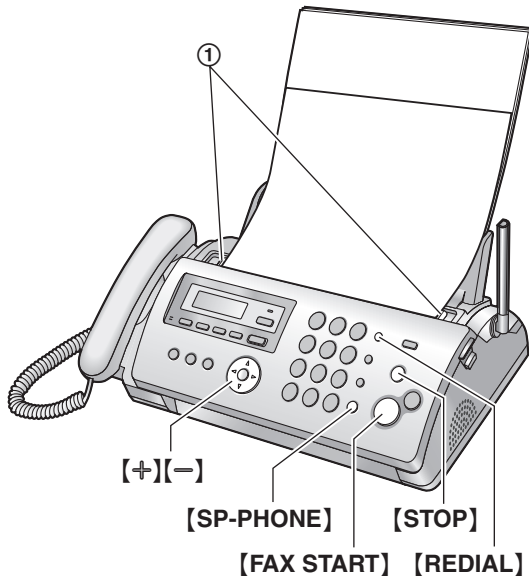

- 1 Adjust the width of the document guides (①) to fit the actual size of the document.
- 2 Insert the document (up to 10 pages) FACE DOWN until a single beep is heard and the unit grasps the document.
- 3 If necessary, press **[+]** or **[-]** repeatedly to select the desired resolution.
- 4 Lift the handset or press **[SP-PHONE]**.
- 5 Dial the fax number.
- 6 **When a fax tone is heard:**
Press **[FAX START]**.

When the other party answers your call:

Ask them to press their start button. When the fax tone is heard, press **[FAX START]**.

To select the resolution

Select the desired resolution according to the character size.

- **"STANDARD"**: For normal-sized characters.
- **"FINE"**: For small-sized characters.
- **"SUPER FINE"**: For very small-sized characters.
- **"PHOTO"**: For photographs, shaded drawings, etc.
- Using the **"FINE"**, **"SUPER FINE"** and **"PHOTO"** settings will increase transmission time.

To redial the last number

[REDIAL] → **[FAX START]**

- If the line is busy, the unit will automatically redial the number 2 or more times.
- To cancel redialling, press **[STOP]**.

To send more than 10 pages at a time

Insert the first 10 pages of the document. Add the other pages (up to 10 at a time) on top of the previously inserted pages while the last page is being fed into the unit.

Pre-dialling a fax number

1. Enter the fax number.
2. Insert the document.
3. **[FAX START]**

Sending from memory (Quick scan feature)

To use this feature, activate feature #34 (page 52) beforehand.

1. Insert the document.
2. Enter the fax number. → **[FAX START]**
 - If the document exceeds the memory capacity, transmission will be cancelled and this feature will be turned OFF automatically. You must send the entire document manually.
 - This feature cannot be used if the handset is being used, or if **[SP-PHONE]** on the base unit, **[↶]** or **[↷]** on the cordless handset is pressed.

To stop sending

Press **[STOP]**.

To send a fax using the cordless handset

1. While talking to the other party, insert the document, then press **[END]**.
2. Select **"Fax Start"**, then press **[OK]**.

Printing a sending report

A sending report provides you with a printed record of transmission results (errors, etc.). To print sending reports, make sure feature #04 is activated (page 50). The default setting is **"ERROR"**. For an explanation of error messages, see page 64.

Printing a journal report

A journal report provides you with a printed record of the 30 most recent fax transmissions and receptions. To print it manually, see page 78. To print it automatically after every 30 new fax transmissions and receptions, make sure feature #22 is activated (page 51). For an explanation of error messages, see page 64.

4.2 Document requirements

Minimum document size

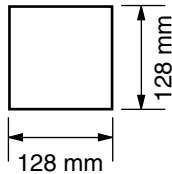

Maximum document size

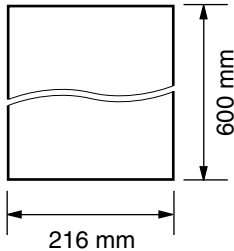

Effective scanning area

- Shaded area will be scanned.

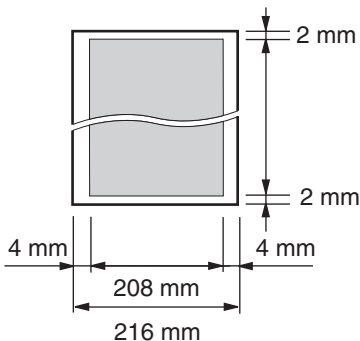

Document weight

- Single sheet:
45 g/m² to 90 g/m²
- Multiple sheets:
60 g/m² to 80 g/m²

Note:

- Remove clips, staples or other fasteners.
- Do not send the following types of documents: (Make a copy of the document using another copier and send the copy.)
 - Chemically treated paper such as carbon or carbonless duplicating paper
 - Electrostatically charged paper
 - Badly curled, creased or torn paper
 - Paper with a coated surface
 - Paper with a faint image
 - Paper with printing on the opposite side that can be seen through the other side, such as newsprint

- Check that ink, paste or correction fluid has dried completely.
- To send a document with a width of less than 210 mm, we recommend using a copy machine to copy the original document onto A4 or letter-sized paper, then sending the copied document.

4.3 Sending a fax using the phonebook and one touch dial

Before using this feature, store the desired names and telephone numbers into the base unit's phonebook (page 26) and the base unit's one touch dial (page 27).

- 1 Adjust the width of the document guides to fit the actual size of the document.
- 2 Insert the document (up to 10 pages) FACE DOWN until a single beep is heard and the unit grasps the document.
- 3 If necessary, press **[+]** or **[-]** repeatedly to select the desired resolution (page 35).

4 Using the phonebook:

1. **[PHONEBOOK]**
2. Press **[+]** or **[-]** repeatedly to display the desired item. → **[FAX START]**

Using one touch dial:

1. Press and hold the desired one touch dial key (**[1]** to **[9]**).
 - You can view other one touch dial assignments by pressing **[+]** or **[-]**.
2. **[FAX START]**

Fax auto redial

If the line is busy or if there is no answer, the unit will automatically redial the number 2 or more times.

- To cancel redialling, press **[STOP]**.

4.4 Broadcast transmission

By storing the base unit's phonebook items (page 26) into the broadcast memory, you can send the same document to multiple parties (up to 20). Your programmed items will remain in the broadcast memory, allowing frequent re-use.

4.4.1 Programming items into the broadcast memory

- 1 Press **[MENU]** repeatedly to display "BROADCAST SET". → **[#]**
- 2 Press **[+]** or **[-]** repeatedly to display the desired item. → **[SET]**
 - The number in brackets indicates the number of registered items.
 - If you have programmed the wrong item, press **[STOP]** to erase the item.
 - To program other items, repeat step 2 (up to 20 items).
- 3 **[SET]**

4.4.2 Adding a new item into the broadcast memory

- 1 **[PHONEBOOK]**
- 2 Press **[+]** or **[-]** repeatedly to display "<BROADCAST>". → **[MENU]** → **[*]**
- 3 Press **[+]** or **[-]** repeatedly to display the desired item. → **[SET]**
 - To add other items, repeat step 3 (up to 20 items).
- 4 **[STOP]**

4.4.3 Erasing a stored item from the broadcast memory

- 1 **[PHONEBOOK]**
- 2 Press **[+]** or **[-]** repeatedly to display "<BROADCAST>". → **[MENU]** → **[#]**
- 3 Press **[+]** or **[-]** repeatedly to display the desired item you want to erase.
 - To cancel erasing, press **[STOP]**.
- 4 **[SET]** → **[SET]** → **[STOP]**

4.4.4 Sending the same document to pre-programmed parties

- 1 Insert the document FACE DOWN.
- 2 If necessary, press **[+]** or **[-]** repeatedly to select the desired resolution (page 35). → **[PHONEBOOK]**
- 3 Press **[+]** or **[-]** repeatedly to display "<BROADCAST>". → **[FAX START]**

- After transmission, the unit will automatically print a report (**Broadcast sending report**).

Note:

- If you select "FINE", "SUPER FINE" or "PHOTO" resolution, the number of pages that the unit can send will decrease.
- If the document exceeds the memory capacity, transmission will be cancelled.
- If a party is busy or does not answer, it will be skipped and redialled later 2 or more times.

To send the same document to a one-time group of items

1. Insert the document. → **[PHONEBOOK]**
2. Press **[+]** or **[-]** repeatedly to display "<ONE TIME BROAD>". → **[SET]**
3. Press **[+]** or **[-]** repeatedly to display the desired party. → **[SET]**
 - If you have programmed the wrong item, press **[STOP]** to erase the item.
 - To program other parties, repeat step 3 (up to 20 items).
4. Press **[FAX START]** to start transmission to the programmed parties.

To cancel broadcast transmission

Press **[STOP]** repeatedly to display "SEND CANCELLED?". → **[SET]**

4.5 Selecting the way to use your fax machine

Depending on your situation, select the way you prefer to use your fax machine.

- Use as a telephone answering machine and/or fax (TAM/FAX mode)
- Use only as a fax (FAX ONLY mode)
- Use mostly as a telephone (TEL mode)

4.5.1 Use as a telephone answering machine and/or fax (TAM/FAX mode)

Your situation

You want to answer phone calls using the telephone answering machine and receive faxes automatically.

Setup

Set the fax machine to TAM/FAX mode (page 40) by pressing **[AUTO ANSWER]** repeatedly.

- The **[AUTO ANSWER]** indicator on the base unit turns ON and  (next to the battery icon) appears on the cordless handset display.

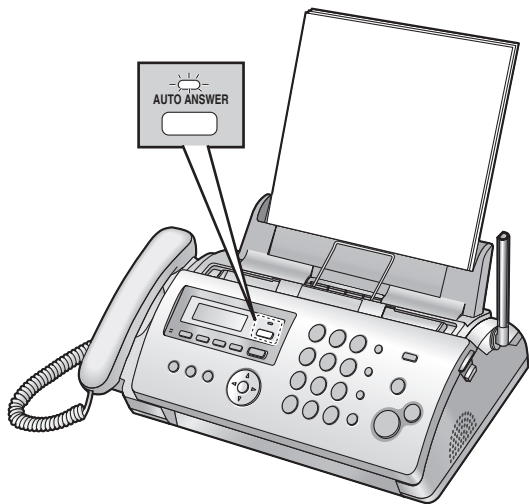

Note:

- Make sure feature #77 is set to “**TAM/FAX**” beforehand (page 55).
- Do not connect an answering machine to the same telephone line. If connected, set the automatic answer feature to OFF by pressing **[AUTO ANSWER]** repeatedly.

How phone calls and faxes are received

If the call is a phone call, the fax machine will record the caller's message automatically.

If a fax calling tone is detected, the fax machine will receive the fax automatically.

4.5.2 Use only as a fax (FAX ONLY mode)

Your situation

You have a separate telephone line just for faxes.

Setup

Set the fax machine to FAX ONLY mode (page 40) by pressing **[AUTO ANSWER]** repeatedly.

- The **[AUTO ANSWER]** indicator on the base unit turns ON and  (next to the battery icon) appears on the cordless handset display.



Note:

- Make sure feature #77 is set to “**FAX ONLY**” beforehand (page 55).

How faxes are received

All incoming calls will be answered as faxes.

4.5.3 Use mostly as a telephone (TEL mode)

Your situation

You want to answer calls by yourself. If a fax call is received, you must receive the fax manually.

Setup

Set the fax machine to TEL mode (page 39) by pressing **[AUTO ANSWER]** repeatedly.

- The **[AUTO ANSWER]** indicator on the base unit turns OFF and  (next to the battery icon) disappears from the cordless handset display.



How to receive phone calls and faxes

You have to answer all calls manually.

To receive a fax, press **[FAX START]**.

4.6 Receiving a fax manually – Auto answer OFF

Note:

- By default, the unit reduces the size of the received document to 92% when printing (See feature #36 on page 53 for details).



4.6.1 Activating TEL mode

Press **[AUTO ANSWER]** repeatedly to display “**TEL MODE**”.

- The **[AUTO ANSWER]** indicator on the base unit turns OFF and  (next to the battery icon) disappears from the cordless handset display.





Activating TEL mode with the cordless handset

-  →  → **OK**
- “Answer Off” → **OK** → 

How to receive phone calls and faxes with the base unit

- Lift the handset or press **[SP-PHONE]** to answer the call.
- When:
 - document reception is required,
 - a fax calling tone (slow beep) is heard, or
 - no sound is heard,
 press **[FAX START]**.
- Replace the handset if using it.

How to receive calls and faxes with the cordless handset

- Lift the cordless handset and press  or  to answer the call.

- When:
 - document reception is required,
 - a fax calling tone (slow beep) is heard, or
 - no sound is heard,
 press .
- Select “**Fax Start**”, then press **OK**.
 - You can also press **[FAX START]** on the base unit.

How to receive faxes with an extension telephone

- When the extension telephone rings, lift the handset of the extension telephone.
- When:
 - document reception is required,
 - a fax calling tone (slow beep) is heard, or
 - no sound is heard,
 press **[*][#][9]** (default fax activation code) **firmly**.
- Replace the handset.

Note:

- To receive fax documents using the extension telephone, you must set the remote fax activation to ON (feature #41 on page 53) beforehand. The default setting is ON.

To stop receiving

Press **[STOP]**.

4.7 Receiving a fax automatically – Auto answer ON

Note:

- By default, the unit reduces the size of the received document to 92% when printing (See feature #36 on page 53 for details).

4.7.1 Activating TAM/FAX mode (Telephone Answering Machine/Fax mode)

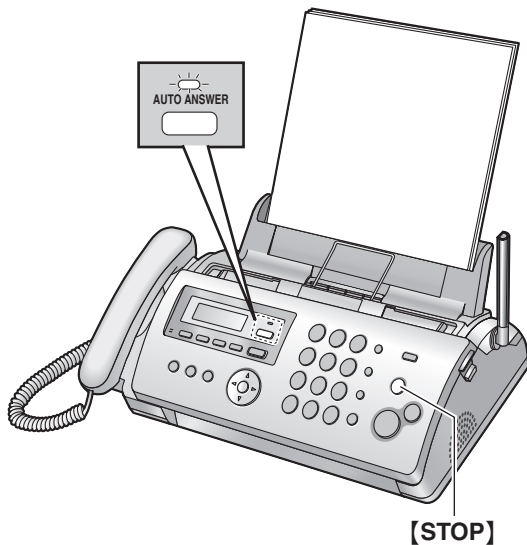

- Make sure feature #77 is set to “**TAM/FAX**” (page 55) beforehand.
- Press **[AUTO ANSWER]** repeatedly to display “**TAM/FAX MODE**”.
 - The **[AUTO ANSWER]** indicator on the base unit turns ON and  (next to the battery icon) appears on the cordless handset display.



Note:

- The maximum incoming message recording time can be changed (page 48, feature #10 on page 51).

Activating TAM/FAX mode with the cordless handset

-  →  → **OK**
- “Answer On” → **OK** → **[*][0]**

Note:

- Make sure feature #77 is set to “**TAM/FAX**” beforehand (page 55).

How phone calls and faxes are received

When receiving calls, the unit works as an answering machine and/or fax.

Note:

- If you answer a call with an extension telephone (if connected to the same line), and the answering machine is answering the call, you can press **[*][0]**

(default auto disconnection code) to speak to the caller.

- The auto disconnection code can be changed in feature #49 on page 54.
- Even when you answer a call with the extension telephone and press the auto disconnection code, the answering machine may continue answering the call depending on the type of an extension telephone. Press **[STOP]** on the fax machine to talk with the calling party.

Receiving a voice message and fax document in one call

The caller can leave a voice message and send a fax document during the same call. Inform the caller of the following procedure beforehand.

- The caller calls your unit.
 - The answering machine will answer the call.
- The caller can leave a message after the greeting message.
- The caller presses **[*][9]**.
 - The unit will activate the fax function.
- The caller presses the start button to send a fax.

Changing the ring count in TAM/FAX mode

You can select from “2” (default), “3”, “4”, “5”, “6”, “7”, or “**AUTO**”. This setting can be changed by feature #06 on page 50, or using the cordless handset (page 48).

- “**AUTO**”: The unit answers after 2 or 3 rings when new messages have been recorded, and after 5 or 6 rings when there are no new messages. If you call your unit from a remote location to listen to new messages (page 48), you will know that there are no messages when the unit rings for the 4th time. You can then hang up without being charged for the call.



Note:

- If you set to “4”, receiving faxes may not be possible.

4.7.2 Activating FAX ONLY mode

- Make sure feature #77 is set to “**FAX ONLY**” (page 55) beforehand.
- Press **[AUTO ANSWER]** repeatedly to display “**FAX ONLY MODE**”.
 - The **[AUTO ANSWER]** indicator on the base unit turns ON and  (next to the battery icon) appears on the cordless handset display.

Activating FAX ONLY mode with the cordless handset

-  →  → **OK**
- “Answer On” → **OK** → **[*][0]**

Note:

- Make sure feature #77 is set to “**FAX ONLY**” beforehand (page 55).

How faxes are received

When receiving calls, the unit will automatically answer all calls and only receive fax documents.

Note:

- The number of rings before a call is answered in FAX ONLY mode can be changed (feature #06 on page 50).
-

4.8 Receive polling (retrieving a fax placed on another fax machine)

This feature allows you to retrieve a document from another compatible fax machine. Therefore you pay for the call.

Make sure that no documents are fed into your unit and that the other party's machine is ready for your call.

- 1 Press **[MENU]** repeatedly to display "POLLING". → **[SET]**
 - 2 Dial the fax number. → **[FAX START]**
-

4.9 Junk fax prohibitor (preventing fax reception from undesired callers)

If you subscribe to Caller ID service (page 28), this feature prevents fax reception from calls that do not show caller information.

Additionally, the fax machine will not accept faxes originated from numbers that match the ones on a programmable junk fax prohibitor list.

Important:

- This feature does not work when manual reception is performed.
-

4.9.1 Activating the junk fax prohibitor

- 1 Press **[MENU]** repeatedly to display "JUNK FAX PROH." → **[▶]**
 - 2 Press **[+]** or **[-]** repeatedly to select "ON". → **[SET]**
 - 3 Press **[MENU]** to exit the program.
-

4.9.2 Storing undesired callers

You can register up to 10 undesired numbers from the Caller ID list (page 29) if you do not wish to receive faxes from them.

- 1 Press **[MENU]** repeatedly to display "JUNK FAX PROH."
- 2 Press **[▶]** repeatedly to display "JUNK LIST SET". → **[SET]**
- 3 Press **[+]** or **[-]** repeatedly to display the item you wish to prevent the fax reception from. → **[SET]**

- 4 Press **[STOP]** to exit the program.
-

To display the junk fax prohibitor list

1. Press **[MENU]** repeatedly to display "JUNK FAX PROH."
 2. Press **[▶]** repeatedly to display "JUNK LIST DISP." → **[SET]**
 3. Press **[+]** or **[-]** to display the item.
 4. Press **[MENU]** to exit the program.
-

To print the junk fax prohibitor list

1. Press **[MENU]** repeatedly to display "JUNK FAX PROH."
 2. Press **[▶]** repeatedly to display "JUNK LIST PRINT". → **[SET]**
 3. Press **[MENU]** to exit the list.
-

To erase an item from the junk fax prohibitor list

1. Press **[MENU]** repeatedly to display "JUNK FAX PROH."
2. Press **[▶]** repeatedly to display "JUNK LIST DISP." → **[SET]**
3. Press **[+]** or **[-]** repeatedly to display the desired item. → **[ERASE]**
 - To cancel erasing, press **[STOP]**, then press **[MENU]**.
4. **[SET]** → **[MENU]**

5.1 Using with the ring detection feature

This feature is only for use if you subscribe to a Distinctive Ring pattern service from your telephone company. For more information on the availability of this service in your area, please contact your telephone company before setting this feature on your unit.

This service is called “Fax Stream Duet”.

The Distinctive Ring service gives you an additional phone number on a single telephone line, with a different ringing pattern.

When you wish to use the additional phone number as a facsimile telephone number, set the ring pattern detection feature to ON. When the unit detects a call matching the Distinctive Ring pattern, it will receive a fax automatically.

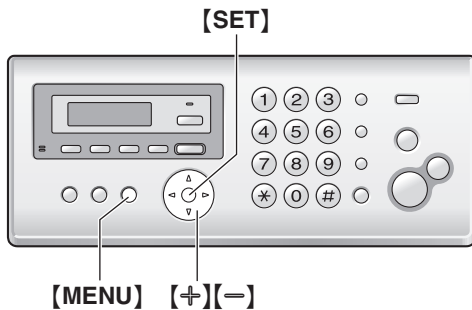

- 1 Press **[MENU]**.
- 2 Press **[*][*]**, then **[3][1]**.
- 3 Press **[+]** or **[-]** to select “ON”.
 - If this feature is not required, select “OFF”.
- 4 Press **[SET]**.
- 5 Press **[MENU]**.

6.1 Making a copy

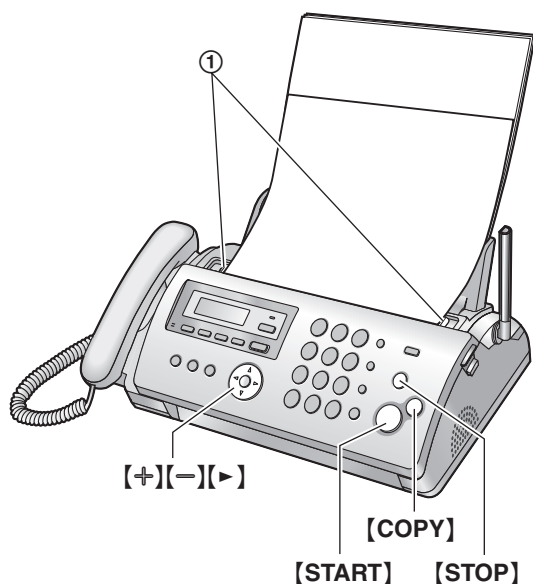

- 1 Adjust the width of the document guides (①) to fit the actual size of the document.
- 2 Insert the document (up to 10 pages) FACE DOWN until a single beep is heard and the unit grasps the document.
- 3 If necessary, press **[+]** or **[-]** repeatedly to select the desired resolution.
 - If you select “STANDARD”, copying will be performed using “FINE” mode.
- 4 **[COPY]**
 - If necessary, enter the number of copies (up to 20).
- 5 Press **[START]**, or the unit will start copying within 15 seconds.
 - The unit will start copying.

Note:

- Any document which can be sent as a fax can also be copied (page 36).

To select the resolution

Select the desired resolution according to the character size.

- “FINE”: For small-sized characters.
- “SUPER FINE”: For very small-sized characters.
- “PHOTO”: For photographs, shaded drawings, etc.

Copying from memory (Quick scan feature)

This feature is helpful when you want to copy the document, then remove it for other uses. To use this feature, activate feature #34 (page 52) beforehand. The default setting is OFF.

- If the document exceeds the memory capacity, copying of the exceeded document will be cancelled and this feature will be turned OFF automatically.

To stop copying

Press **[STOP]**.

6.1.1 More copying features

To enlarge a document

1. Insert the document.
2. **[COPY]** → **[>]**
3. Press **[+]** repeatedly to select “150%” or “200%”. → **[START]**
 - The unit will enlarge the centre of the upper part of the document. To make an enlarged copy of the bottom of the document, turn the document around, and then make a copy.

Example: 150% enlarged copy

Original document

Enlarged copy

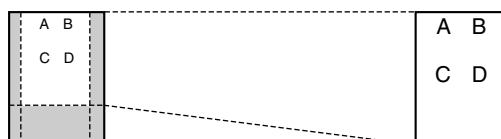

To reduce a document

1. Insert the document.
2. **[COPY]** → **[>]**
3. Press **[-]** repeatedly to select “92%”, “86%” or “72%”, then press **[START]**.

Setting	Recording paper size	Original document size
“100%” (default)	A4	A4, Letter
“92%”	A4	A4
“86%”	A4	A4
“72%”	A4	Legal

Note:

- If the image at the bottom of the document is not copied when you copy a document that is the same length as the recording paper, try 92% or 86%.

To collate multiple copies

The unit can collate multiple copies in the same order as the original document pages.

1. Insert the document.
2. **[COPY]**
3. Enter the number of copies (up to 20).
4. Press **[>]** 2 times to display “COLLATE OFF”.

6. Copy

5. Press **[+]** or **[-]** repeatedly to display “**COLLATE ON**”. → **[START]**

Example: Making 2 copies of a 4-page original document

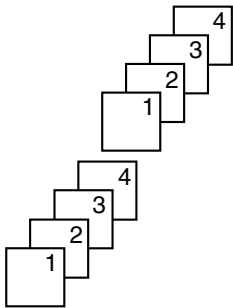

Collated pages

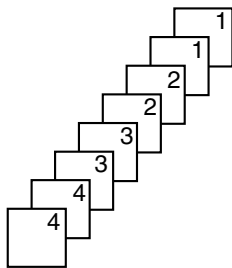

Uncollated pages

Note:

- The unit will store the documents into memory while collating the copies. If memory becomes full while storing, the unit will only print out the stored pages.

7.1 Recording your greeting message

The unit has a pre-recorded greeting message for TAM/FAX mode. If you record your own greeting message, it will be played instead of the pre-recorded greeting message when a call is received. The maximum recording time of your greeting message is either 16 seconds (default) or 60 seconds. We recommend you record a message of less than 12 seconds to make it easier to receive faxes. Make sure feature #77 is set to “**TAM/FAX**” beforehand (page 55).

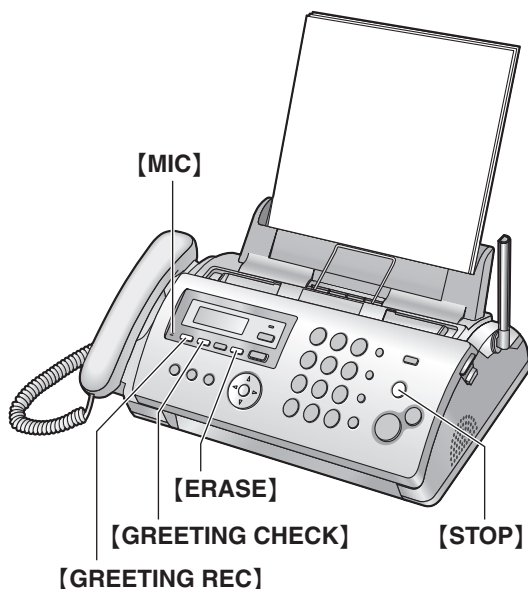

- 1 **[GREETING REC]**
 - A long beep will sound.
- 2 Speak clearly about 20 cm away from **[MIC]**.
- 3 When finished recording, press **[STOP]**.

Note:

- You can change the maximum TAM/FAX greeting message time to 60 seconds (feature #54 on page 54).
 - If you change the setting to 60 seconds, we recommend that you tell the caller in your TAM/FAX greeting message to press ✕9 before starting the fax transmission.
 - If you change the setting from 60 seconds to 16 seconds, your current greeting message will be deleted. The pre-recorded greeting message will be played when a call is received.
- If you change the maximum recording time of incoming messages to “**GREETING ONLY**” (page 48, feature #10 on page 51), the unit will answer a call with your current greeting message, and then hang up. Re-record your greeting message to inform

the caller that the unit will not record any incoming messages.

To check the greeting message

Press **[GREETING CHECK]**.

- The unit will play the greeting message.

7.1.1 Erasing your recorded greeting message

1 **[GREETING CHECK]**

- To cancel erasing, press **[STOP]**.

2 **[ERASE]**

Note:

- If you erase your TAM/FAX greeting message, the pre-recorded greeting message will be played when a call is received.

7.2 Listening to recorded messages

When the unit has recorded new voice messages:

- The **[AUTO ANSWER]** indicator will flash when auto answer is turned ON.
- The total number of recorded messages will flash on the base unit display.

7.2.1 To play back messages

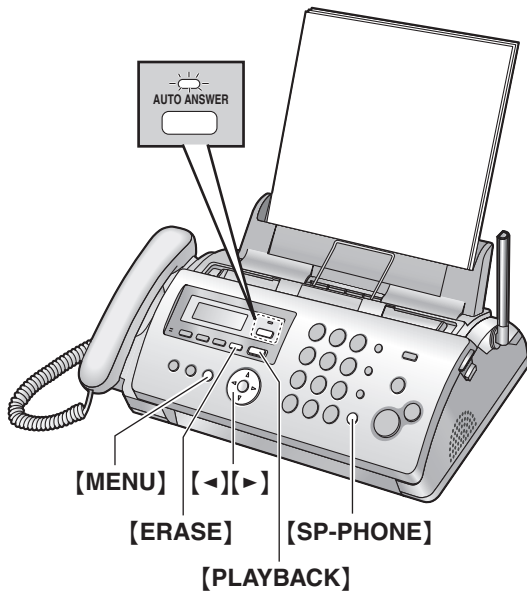

Press **[PLAYBACK]**.

- Only new messages will be played.
- After playing back all of the new messages, the **[AUTO ANSWER]** indicator will stop flashing but will remain lit up when auto answer is turned ON. If you press **[PLAYBACK]** at this time, all the recorded messages will be played.

7.2.2 Useful features during playback

To repeat a message

Press **[-]** while listening to the message.

- If you press **[-]** within 5 seconds of the beginning of the message, the previous message will be played.
- To play back a specific message, press **[-]** or **[>]** and search for the message you want to listen to.

To skip a message

Press **[>]** to play the next message.

Voice time/day stamp

During playback, the unit will announce the day of the week and time that each message was recorded.

If you subscribe to Caller ID service

During playback, you can call back the displayed name or number using the base unit.

1. Press **[MENU]** during playback.
 - The base unit stops playback.
 - If you do not need to edit the telephone number, skip to step 3.
2. Edit the telephone number (page 30).
3. Lift the handset or press **[SP-PHONE]**.

7.2.3 Erasing recorded messages

To erase a specific message

Press **[ERASE]** while listening to the message you want to erase.

To erase all messages

1. **[ERASE]**
2. Within 5 seconds, press **[ERASE]**.

7.3 Leaving a message for others or yourself

You can record a voice memo to leave a private message for yourself or someone else. Recorded messages are treated as new messages.

1 [MEMO]

- A long beep will sound.

2 Speak clearly about 20 cm away from [MIC].

3 To stop recording, press [STOP].

Note:

- If you record for over 3 minutes, the unit will stop recording.

7.4 Using the answering machine with the cordless handset

Helpful hints:

- To activate TAM/FAX mode with the cordless handset, see page 40.

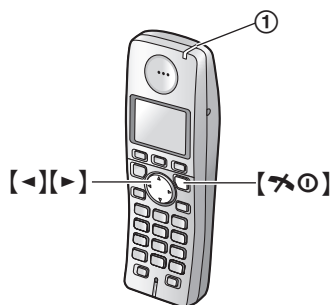

7.4.1 Recording your greeting message

- Press **[M]** → **[R]** → **OK**
- “Record Greeting” → **OK**
 - Hold the cordless handset about 20 cm away and speak clearly into the microphone.
- Press **[P]** to stop recording. → **[*0]**

To check the greeting message

- [M]** → **[R]** → **OK**
- “Play Greeting” → **OK** → **[*0]**

To erase your greeting message

- [M]** → **[R]** → **OK**
- “Erase Message” → **OK**
- “Erase Greeting” → **OK**
- “Yes” → **OK** → **[*0]**

7.4.2 Listening to recorded messages

When the unit has new voice messages:

- the message indicator (①) on the cordless handset will flash if the message alert feature (page 56) is turned ON
- [M]** will be displayed
- the total number of new messages will be displayed next to **[M]**

- [M]** → **[R]** → **OK**
- “Play New Msg.” or “Play All Msg.” → **OK**

To repeat a message

Press **[<]** while listening to the message.

- If you press **[<]** within 5 seconds of the beginning of the message, the previous message will be played.

To skip a message

Press **[>]** to play the next message.

To stop playback

Press **[P]**.

If you subscribe to Caller ID service

During playback, you can call back the displayed name or number using the cordless handset.

- Press **[M]** during playback.
- “Call Back” → **OK**

Note:

To edit the number before calling back;

- Press **[M]** during playback.
- “Edit and Call” → **OK**
- Edit the number. → **OK**

7.4.3 Erasing recorded messages

To erase a specific message

- Press **[X]** while listening to the message you want to erase.
- “Yes” → **OK**

To erase all messages

- [M]** → **[R]** → **OK**
- “Erase Message” → **OK**
- “Erase All” → **OK**
- “Yes” → **OK** → **[*0]**

7.4.4 Direct command operation

You can operate the answering machine by pressing dial keys, rather than navigating through the menus. To use the following commands, press **[M]**. → **[R]** → **OK**

Key	Direct commands
[1]	Repeats a message (during playback) ^{*1}
[2]	Skips a message (during playback)
[3]	Enter the “Settings” menu
[4]	Plays new messages
[5]	Plays all messages
[6]	Plays greeting message
[7][6]	Records greeting message
[8]	Turns ON auto answer setting
[9]	Stops current operation
[0]	Turns OFF auto answer setting

7. Answering Machine

Key	Direct commands
[*][4]	Erases a specific message (during playback)
[*][5]	Erases all messages
[*][6]	Erases greeting message (during greeting message playback)

*1 If pressed within the first 5 seconds of a message, the previous message will be played.

7.4.5 Programming for answering machine

To set the remote operation ID

You must program a remote operation ID to operate the answering machine from a remote location (page 48).

1. **[]** → **[]** → **OK**
2. “Settings” → **OK**
3. “Remote Code” → **OK**
4. To activate the remote operation feature, enter a 3-digit remote operation ID.
 - To deactivate the remote operation feature, press **[*]**.
5. **OK** → **[]**

Note:

- You can also program this feature with the base unit (feature #11 on page 51).

To change the ring count in TAM/FAX mode

To change the number of rings before the unit answers a call in TAM/FAX mode. You can select 2 to 7 rings or “Auto”. See page 40 for details.

1. **[]** → **[]** → **OK**
2. “Settings” → **OK**
3. “Number of Rings” → **OK**
4. Select the desired setting. → **OK** → **[]**

Note:

- You can also program this feature with the base unit (feature #06 on page 50).

To change the maximum recording time for incoming messages

You can change the maximum message recording time allotted to each caller, or set the unit to greet callers but not record messages.

1. **[]** → **[]** → **OK**
2. “Settings” → **OK**
3. “Recording Time” → **OK**
4. Select the desired setting. → **OK** → **[]**

Note:

- You can also program this feature with the base unit (feature #10 on page 51).

To screen the incoming call

To hear an incoming call from the speaker when the answering machine is recording the message.

1. **[]** → **[]** → **OK**
2. “Settings” → **OK**
3. “Call Screening” → **OK**
4. “On” or “Off” → **OK** → **[]**

Note:

- You can also program this feature with the base unit (feature #67 on page 54).

7.5 Operating from a remote location

Important:

- Program the remote operation ID beforehand (page 48, or feature #11 on page 51).
- Set the unit to TAM/FAX mode before going out (page 40).
- Use a touch tone telephone for remote operations.

7.5.1 Summary of remote operation

- 1 Call your unit.
- 2 Enter the remote operation ID during or after the TAM/FAX greeting message.
- 3 **When there are new recorded messages**
 1. A long beep will sound.
 2. Short beep(s) will sound up to 8 times.
 - This indicates the number of new messages.
 3. New messages will be played back.
- 4 **When there are no new messages**
 1. A long beep will sound (short beep will not sound).
 2. Press **[5]**.
 3. All the recorded messages will be played back.
- 4 To end remote operation press **[9]**, then hang up.

7.5.2 Remote operation using remote commands

- 1 Call your unit.
- 2 Enter the remote operation ID during or after the TAM/FAX greeting message.
- 3 Enter a remote command within 10 seconds.

Note:

- When you press a key, press firmly.

Key	Remote command
[1]	Repeats a message (during playback) ^{*1}
[2]	Skips a message (during playback)
[4]	Plays new messages
[5]	Plays all messages
[6]	Plays greeting message
[7]	Records greeting message
[9]	Stops current operation ^{*2}
[0]	Turns OFF auto answer setting
[*][4]	Erases a specific message (during playback)
[*][5]	Erases all messages
[*][6]	Erases greeting message (during greeting message playback)
[*][#]	Ends remote operation
[#]	Skips the greeting message

*1 If pressed within the first 5 seconds of a message, the previous message will be played.

*2 To resume operation, press a command key within 10 seconds.

Recording a marker message

After playing back the messages, you can leave an additional message.

1. Wait for 3 beeps indicating the end of the remote operation.
2. Wait about 10 seconds.
3. Hear the voice guide.
4. Hear 1 beep.
5. Leave a message.

To turn ON the auto answer setting

1. Call your unit and let it ring 10 rings.
 - A beep will sound.
2. Enter the remote operation ID (page 48, feature #11 on page 51) within 10 seconds.
 - The receiving mode will be set to TAM/FAX or FAX ONLY mode, depending on the setting of feature #77 (page 55).
3. Hang up the handset.

Note:

- You cannot turn ON the auto answer setting in the following cases:
 - when the unit is set to TEL mode and during night mode (page 24, feature #35 on page 52).

8.1 Base unit programming

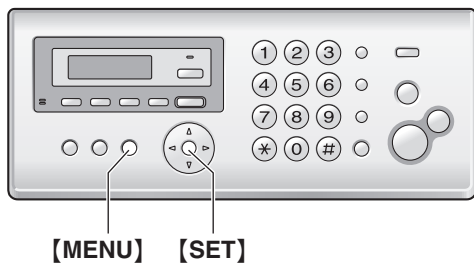

1. **[MENU]**
2. Press **[*]** and the 2-digit code.
3. Press the desired command to display the desired setting.
 - This step may be slightly different depending on the feature.
4. **[SET]**
5. To exit programming, press **[MENU]**.

8.1.1 Basic features

Feature	Feature code	Selection
Setting the date and time* ¹	[*][0][1]	Enter the date and time using the dial keypad. See page 20 for details.
Setting your logo	[*][0][2]	Enter your logo using the dial keypad. See page 21 for details.
Setting your fax number	[*][0][3]	Enter your fax number using the dial keypad. See page 21 for details.
Printing a sending report	[*][0][4]	<p>[0] "OFF": Sending reports will not be printed.</p> <p>[1] "ON": A sending report will be printed after every fax transmission.</p> <p>[2] "ERROR" (default): A sending report will be printed only when a fax transmission fails.</p>
Changing the ring count in FAX ONLY mode	[*][0][6]	<p>[2] "2" (default)</p> <p>[3] "3"</p> <p>[4] "4"</p> <p>[5] "5"</p> <p>[6] "6"</p> <p>[7] "7"</p> <p>[8] "8"</p> <p>[9] "9"</p> <p>Note:</p> <ul style="list-style-type: none"> • Set feature #77 to "FAX ONLY" (page 55) beforehand.
Changing the ring count in TAM/FAX mode* ¹	[*][0][6]	<p>[0] "AUTO"</p> <p>[2] "2" (default)</p> <p>[3] "3"</p> <p>[4] "4"</p> <p>[5] "5"</p> <p>[6] "6"</p> <p>[7] "7"</p> <p>See page 40 for details.</p> <p>Note:</p> <ul style="list-style-type: none"> • Set feature #77 to "TAM/FAX" (page 55) beforehand. • You can also program this feature with the cordless handset (page 48).

Feature	Feature code	Selection
Changing the maximum recording time for incoming messages* ¹	[*][1][0]	<p>[1] "1 MINUTE"</p> <p>[2] "GREETING ONLY": The unit plays the greeting message but does not record any incoming messages.</p> <p>[3] "3 MINUTES" (default)</p> <p>Note:</p> <ul style="list-style-type: none"> You can also program this feature with the cordless handset (page 48).
Setting the remote operation ID* ¹	[*][1][1]	<p>1. [MENU] → [*][1][1]</p> <p>2. To activate the remote operation feature, enter a 3-digit remote operation ID.</p> <ul style="list-style-type: none"> To deactivate the remote operation feature, press [*]. <p>3. [SET] → [MENU]</p> <p>Note:</p> <ul style="list-style-type: none"> You can also program this feature with the cordless handset (page 48).
Setting the ringtone for outside calls* ²	[*][1][7]	<p>[1] "RINGTONE 1" (default)</p> <p>[2] "RINGTONE 2"</p> <p>[3] "RINGTONE 3"</p> <p>[4] "RINGTONE 4"</p> <p>[5] "RINGTONE 5"</p> <p>[6] "RINGTONE 6"</p>

*1 When this setting is changed using the base unit, the setting for the cordless handset will also be changed, and vice versa.

*2 This setting can be changed individually for the base unit and the cordless handset.

- To set the cordless handset ringtone for outside calls, see page 56.

8.1.2 Advanced features

Feature	Feature code	Selection
Setting the journal report to print automatically	[*][2][2]	<p>[0] "OFF": The unit will not print a journal report, but will keep a record of the last 30 fax transmissions and receptions.</p> <p>[1] "ON" (default): The unit will print a journal report automatically after every 30 new fax transmissions and receptions (page 35).</p>
Sending documents overseas	[*][2][3]	<p>If you cannot send a fax overseas even if the number is correct and the line is connected, activate this feature before sending the fax.</p> <p>This feature improves the reliability by reducing the transmission speed.</p> <p>[0] "OFF": Deactivates this feature.</p> <p>[1] "NEXT FAX": This setting is effective only for the next attempted fax transmission. After transmission, the unit will return to the previous setting.</p> <p>[2] "ERROR" (default): When the previous fax transmission fails and you wish to re-send the document.</p> <p>Note:</p> <ul style="list-style-type: none"> Calling charges may be higher than usual.

8. Programmable Features

Feature	Feature code	Selection
Sending a fax at a specified time	[*][2][5]	<p>This feature allows you to take advantage of low-cost calling hours offered by your telephone company. This feature can be set up to 24 hours in advance of the desired time.</p> <p>[0] “OFF” (default) [1] “ON”</p> <p>To send a document:</p> <ol style="list-style-type: none"> 1. Insert the document. 2. If necessary, press [+] or [-] repeatedly to select the desired resolution (page 35). 3. [MENU] → [*][2][5] 4. Press [1] to select “ON”. → [SET] 5. Enter the fax number. → [SET] 6. Enter the transmission start time. <ul style="list-style-type: none"> • If you select 12-hour time entry (page 20), press [*] repeatedly to select AM or PM. • If you select 24-hour time entry (page 20), the time is set using 24-hour time entry. 7. [SET] → [MENU] <p>Note:</p> <ul style="list-style-type: none"> • To cancel after programming, press [STOP] then [SET].
Setting the Caller ID list to print automatically	[*][2][6]	<p>[0] “OFF” (default): The Caller ID list will not be printed automatically, but the base unit will keep a record of the information for the last 50 callers.</p> <p>[1] “ON”: The Caller ID list will be printed automatically each time the base unit logs 50 callers (page 29).</p>
Activating the Distinctive Ring feature	[*][3][1]	<p>[1] “ON” [2] “OFF” (default) See page 42 for details.</p>
Setting the quick scan	[*][3][4]	<p>This feature is helpful when you want to remove the document for other uses, because the unit will release the document before sending or copying.</p> <p>[0] “OFF” (default): Deactivates this feature. [1] “ON”: The unit will scan the document and store it into memory first, then the unit will start sending or copying the documents.</p> <p>Note:</p> <ul style="list-style-type: none"> • If the document exceeds the memory capacity, sending of the whole document or copying of the exceeded document will be cancelled and this feature will be turned OFF automatically.
Setting the night mode^{*2}	[*][3][5]	See page 25 for details.

Feature	Feature code	Selection															
Receiving oversized documents	【#】[3][6]	<p>If the size of the document sent by the other party is as large as or larger than the recording paper, the unit can reduce the document and print it. Select the desired reduction rate.</p> <p>【1】“72%” 【2】“86%” 【3】“92%” (default) 【4】“100%”</p> <table border="1"> <thead> <tr> <th>Setting</th> <th>Recording paper size</th> <th>Original document size</th> </tr> </thead> <tbody> <tr> <td>“100%”</td> <td>A4</td> <td>Letter</td> </tr> <tr> <td>“92%” (default)</td> <td>A4</td> <td>A4</td> </tr> <tr> <td>“86%”</td> <td>A4</td> <td>A4</td> </tr> <tr> <td>“72%”</td> <td>A4</td> <td>Legal</td> </tr> </tbody> </table> <p>Note:</p> <ul style="list-style-type: none"> The information of the sending party is printed on the top of each page. Therefore, even if the original document is the same size as the recording paper, the document will be divided into 2 sheets when printed at “100%”. Select “92%” to print on 1 sheet. 	Setting	Recording paper size	Original document size	“100%”	A4	Letter	“92%” (default)	A4	A4	“86%”	A4	A4	“72%”	A4	Legal
Setting	Recording paper size	Original document size															
“100%”	A4	Letter															
“92%” (default)	A4	A4															
“86%”	A4	A4															
“72%”	A4	Legal															
Changing the LCD display contrast ²	【#】[3][9]	<p>【1】“NORMAL” (default) 【2】“DARKER”</p>															
Changing the fax activation code	【#】[4][1]	<p>If you wish to use an extension telephone (page 39) to receive faxes, activate this feature and program the activation code.</p> <p>【0】“OFF” 【1】“ON” (default)</p> <ol style="list-style-type: none"> 【MENU】 → 【#】[4][1] Press 【1】 to select “ON”. → 【SET】 Enter your code from 2 to 4 digits, using 0-9, 【*】 and 【#】. <ul style="list-style-type: none"> The default code is “*#9”. 【SET】 → 【MENU】 															
Setting the memory reception alert	【#】[4][4]	<p>To alert you with a beeping sound when a received fax document is stored into memory due to some existing problem.</p> <p>【0】“OFF”: Deactivates this feature. 【1】“ON” (default): You will hear a beeping sound.</p> <p>Note:</p> <ul style="list-style-type: none"> The slow beeps will continue until you clear the printing problem and make sure the unit is supplied with enough paper to print the stored document. 															
Setting friendly reception	【#】[4][6]	<p>To receive a fax automatically when you answer a call and hear a fax calling tone (slow beep).</p> <p>【0】“OFF”: You have to press 【FAX START】 for fax reception. 【1】“ON” (default): You do not have to press 【FAX START】 for fax reception.</p>															

8. Programmable Features

Feature	Feature code	Selection
Setting the auto disconnection	[*][4][9]	To answer a call with an extension telephone in TAM/FAX mode (page 40), activate this feature and program the code. [0] "OFF" [1] "ON" (default) 1. [MENU] → [*][4][9] 2. Press [1] to select "ON". → [SET] 3. Enter your code from 2 to 4 digits, using 0-9 and [*] . <ul style="list-style-type: none"> The default code is "*0". 4. [SET] → [MENU]
Changing the greeting message time for TAM/FAX	[*][5][4]	[1] "16s" (default): Maximum greeting message time is 16 seconds. [2] "60s": Maximum greeting message time is 60 seconds. See page 45 for details.
Setting the scan contrast	[*][5][8]	To send or copy a document with faint or dark writing, set this feature before transmission or copying. [1] "NORMAL" (default): Used for normal writing. [2] "LIGHT": Used for dark writing. [3] "DARKER": Used for faint writing.
Copying phonebook data from the base unit to the cordless handset	[*][5][9]	[1] "1 ITEM" (default) [2] "ALL ITEMS" See page 61 for details.
Screening the incoming call^{*1}	[*][6][7]	To hear an incoming call from the speaker when the answering machine is recording the message. [0] "OFF" [1] "ON" (default) Note: <ul style="list-style-type: none"> You can also program this feature with the cordless handset (page 48).
Setting the Error Correction Mode (ECM)	[*][6][8]	This feature is available when the transmitting/receiving fax machines are ECM compatible. [0] "OFF": Deactivates this feature. [1] "ON" (default): If there is an error during fax transmission/reception, the fax machine will support the communication. Note: <ul style="list-style-type: none"> You cannot change the setting when received documents are in memory.

Feature	Feature code	Selection
Setting recall/flash time (for the base unit and cordless handset)	[*][7][2]	<p>The recall/flash time depends on your telephone exchange or host PBX.</p> <p>[1] "900msec." [2] "700msec." [3] "600msec." [4] "400msec." [5] "300msec." [6] "250msec." [7] "200msec." [8] "160msec." [9] "110msec." [*] "100msec." (default) [0] "90msec." [*] "80msec."</p> <p>Note:</p> <ul style="list-style-type: none"> • If the unit is connected via a PBX, this setting may need to be changed in order for PBX functions (transferring a call, etc.) to work correctly. Consult your PBX supplier for the correct setting.
Setting the connecting tone	[*][7][6]	<p>If you often have trouble when sending faxes, this feature allows you to hear connecting tones: fax tone, ring back tone and busy tone. You can use those tones to confirm the status of the other party's machine.</p> <p>[0] "OFF": Deactivates this feature. [1] "ON" (default): You will hear connecting tones.</p> <p>Note:</p> <ul style="list-style-type: none"> • If the ring back tone continues, the other party's machine may not be a fax machine or may have run out of paper. Check with the other party. • The connecting tone volume cannot be adjusted.
Changing the receiving mode in the AUTO ANSWER setting	[*][7][7]	<p>[1] "TAM/FAX" (default): Telephone Answering Machine/Fax mode (page 40) [2] "FAX ONLY": Fax only mode (page 40)</p>
Resetting advanced features to their default settings	[*][8][0]	<p>[0] "NO" (default) [1] "YES"</p> <p>To reset the advanced features:</p> <ol style="list-style-type: none"> 1. [MENU] → [*][8][0] 2. Press [1] to select "YES". → [SET] → [SET] <p>Note:</p> <ul style="list-style-type: none"> • The ECM selection (feature #68 on page 54) will not be reset.

*1 When this setting is changed using the base unit, the setting for the cordless handset will also be changed, and vice versa.

*2 This setting can be changed individually for the base unit and the cordless handset.

- To set the cordless handset night mode, see page 24.
- To change the cordless handset LCD display contrast, see page 56.

8.2 Cordless handset programming

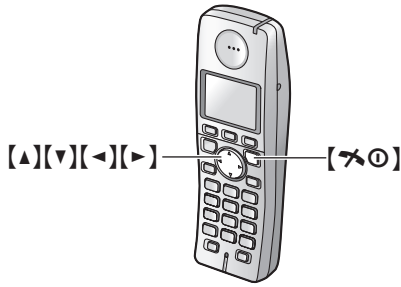

- 1.
2. Select by pressing [**▲**], [**▼**], [**◀**], or [**▶**]. → **OK**
3. Press [**▲**] or [**▼**] to select the desired item in the cordless handset settings menu. → **OK**
4. Press [**▲**] or [**▼**] to select the desired item in the sub-menu. → **OK**
 - In some cases, you may need to select from a second sub menu. → **OK**
5. Press [**▲**] or [**▼**] to select the desired setting then press **OK** or follow the instruction in the rightmost column of the chart.
 - To exit the operation, press [**☎**].



8.2.1 Cordless handset features

Cordless handset settings menu	Sub-menu	Sub-menu 2	Feature (default setting)	
"Time Settings"	"Set Date & Time" ^{*1}	—	Date and time: page 20	
	"Alarm"	—	Set the alarm: page 58	
"Ringer Setup"	"Ringer Volume" ^{*2}	—	Cordless handset ringer volume: page 19 ^{*1}	
	"Ext. Ringtone" ^{*2}	—	Ringtones for outside calls ("Ringtone 1") ^{*3}	
	"Int. Ringtone"	—	Ringtones for intercom calls ("Ringtone 3") ^{*4}	
	"Night Mode" ^{*2}	"Start/End"		(23:00/06:00): page 24
		"On/Off"		("Off"): page 24
"Ring Delay"			("60 sec."): page 24	
"Select Category"			page 24	
"Display Setup"	"Wallpaper"	—	("Wallpaper1")	
	"Display Colour"	—	("Colour1")	
	"Standby Display"	—	Standby mode display ("Off") ^{*5}	
	"Select Language"	—	Display language ("English"): page 58	
	"Contrast" ^{*2}	—	LCD display contrast ("Contrast 3")	
"Registration"	"Register H.set"	—	page 59	
"Select Base"	—	—	Select a base unit ("Auto"): page 59	
"Other Options"	"New Msg. Alert"	—	New message alert ("Off") ^{*6}	
	"Keytones"	—	Keytones ON/OFF ("On")	
	"Auto Talk"	—	Auto talk ON/OFF ("off") ^{*7}	

- When the ringer volume is turned OFF,  is displayed.
When the ringer is turned OFF, the cordless handset will ring:
 - at the minimum level for alarm and intercom calls
 - at the maximum level for paging
- *1 When this setting is changed using the cordless handset, the setting for the base unit will also be changed, and vice versa.
- *2 This setting can be changed individually for the base unit and the cordless handset.
 - To set the base unit ringer volume, see page 19.
 - To set the base unit ringtone for outside calls, see feature #17 on page 51.
 - To set the base unit night mode, see feature #35 on page 25.
 - To set the base unit LCD display contrast, see feature #39 on page 53.
- *3 If you select one of the melody ringtones, the ringtone will continue to sound for several seconds if the caller hangs up before you answer. You may hear a dial tone or no one on the line when you answer a call.
The preset melodies in this product are used with permission of © 2004 M-ZoNE Co., Ltd.
- *4 The preset melodies in this product are used with permission of © 2004 M-ZoNE Co., Ltd.
- *5 If “off” is selected, only current date and time are displayed.
If “**Handset Number**” is selected and the current cordless handset number is 2, “[2]” is displayed.
If “**Base Number**” is selected and the current base unit number is 2, “-2-” is displayed.
- *6 This feature alerts you when new messages have been received or recorded:
 - SMS (page 31)
 - Telephone answering machine (page 47)

The message indicator on the cordless handset flashes until you have read or listened to all new messages.
While message alert is ON, battery operating time is shortened (page 18).
- *7 Auto talk feature allows you to answer calls simply by lifting the cordless handset OFF the charger. You do not need to press [].

Using the base unit PIN/repeater

1. 
2. Select  by pressing [**▲**], [**▼**], [**◀**], or [**▶**]. → **OK**
3. Press [**▲**] or [**▼**] to select the desired item in the base unit settings menu. → **OK**
4. Press [**▲**] or [**▼**] to select the desired item in the sub-menu. → **OK**
5. Press [**▲**] or [**▼**] to select the desired setting then press **OK** or follow the instruction in the rightmost column of the chart.
 - To exit the operation, press [**✕**].

Base unit settings menu	Sub-menu	Feature (default setting)
“Call Options”	“Call Restrict”	page 58
“Other Options”	“Base Unit PIN”	Change base unit PIN (“0000”). ^{*1} – Enter the current 4-digit base unit PIN. ^{*2} → Enter the new 4-digit base unit PIN. → OK
	“Repeater Mode”	(“off”): page 60

*1 If you change the PIN, please make note of your new PIN. The unit will not reveal the PIN to you.

*2 If you forget your PIN, consult your nearest Panasonic service centre.

8. Programmable Features

8.2.2 Time settings

Alarm

An alarm will sound for 3 minutes at the set time once or daily. Set the date and time beforehand (page 20).

1. → → **OK**
2. “Time Settings” → **OK**
3. “Alarm” → **OK** 2 times
4. Select an alarm mode. → **OK**

“Off”	Turns alarm OFF. Press OK again, then press [✕ 0] to finish.
“Once”	The alarm sounds once at the set time. Enter the desired day and month.
“Daily”	An alarm sounds daily at the set time.

5. Enter the desired hour and minute. → **OK**
6. Select the desired ringtone. → **OK**
7. “Save” → **OK** → [**✕** **0**]
 - When the alarm is set, is displayed.

Note:

- To stop the alarm, press any dial key.
- When in talk or intercom mode, the alarm will not sound until the call has ended.
- If you select “Once”, the setting will change to “Off” after the alarm sounds.

8.2.3 Display Setup

Display language

1. [**✕** **0**] →
2. Select by pressing [**▲**], [**▼**], [**◀**], or [**▶**]. → **OK**
3. Press [**▲**] or [**▼**] to select “Display Setup”. → **OK**
4. Press [**▲**] or [**▼**] to select “Select Language”. → **OK**
5. Press [**▲**] or [**▼**] to select the desired language. → **OK** → [**✕** **0**]

Note:

- If you select a language you cannot read, press [**✕** **0**], , press [**▼**], press **OK**, press [**▼**] 2 times, press **OK**, press [**▼**] 3 times, press **OK**, select the desired language, then press **OK**. Press [**✕** **0**].

8.2.4 Call options

Setting call restriction

You can restrict selected cordless handsets/base unit from dialling certain numbers. You can assign up to 6 phone numbers to be restricted, and select which cordless handsets/base unit will be restricted. Storing area codes here will prevent the restricted cordless

handsets/base unit from dialling any phone number in that area code.

1. → → **OK**
2. “Call Options” → **OK**
3. “Call Restrict” → **OK**
4. Enter “0000” (default base unit PIN).
 - If you forget your PIN, contact our service personnel.
5. **To restrict the base unit**, press [**0**].
To restrict a cordless handset, press the desired cordless handset number.
 - All the registered cordless handset numbers will be displayed.
 - Flashing numbers indicate call restriction is turned ON for the corresponding cordless handset/base unit.
 - To turn call restriction OFF for a cordless handset/base unit, press the number again. The number will stop flashing.
6. **OK**
7. Select a memory location. → **OK**
8. Enter the phone number or area code to be restricted (up to 8 digits). → **OK** → [**✕** **0**]
 - To erase a restricted number, press [**C**/**✕**].

9.1 Operating additional units

9.1.1 Additional cordless handsets

Up to 6 cordless handsets can be registered to a single base unit. Additional cordless handsets will give you the freedom to, for example, have an intercom call with another cordless handset while a third cordless handset is on an outside call.

Important:

- **The additional cordless handset model recommended for use with this unit is noted on page 9. If other model cordless handset is used, certain operations (cordless handset settings, base unit settings, etc.) may not be available.**

9.1.2 Additional base units

Cordless handsets can be registered to up to 4 base units, allowing you to add additional base units and extend the area in which your cordless handset(s) can be used. If a cordless handset moves out of range of its base unit when "Auto" is selected on base unit selection (page 59), it will look for another base unit to make or receive calls. A base unit and the cordless handsets it communicates with is called a "radio cell".

Note:

- Calls will be disconnected when the cordless handset moves from one radio cell to another.

9.2 Registering a cordless handset to a base unit

The included cordless handset and base unit are preregistered. If for some reason the cordless handset is not registered to the base unit (for example, Υ flashes even when the cordless handset is near the base unit), register the cordless handset manually.

After purchasing an additional cordless handset, register it to the base unit. Ensure that the additional cordless handset is switched ON. If it is not ON, press and hold **[Υ]** for few seconds to turn the cordless handset ON.

- 1 **[Υ]** → **[Υ]** → **OK**
- 2 "Registration" → **OK**
- 3 "Register H.set" → **OK**
- 4 Select a base unit number. → **OK**
 - This number is used by the cordless handset as a reference only.
- 5 Press and hold **[LOCATOR]** on the base unit for about 3 seconds, until the registration tone sounds.
 - After pressing **[LOCATOR]**, the rest of this procedure must be completed within 1 minute.
- 6 Wait until "Enter Base PIN" is displayed, then enter the base unit PIN (default: "0000"), then press **OK**.

- If you forget your PIN, consult your nearest Panasonic service centre.
- When the cordless handset has been registered successfully, Υ will stop flashing. If keytones are turned ON (page 56), a confirmation tone will be heard.

Note:

- Charge the batteries of your additional cordless handset for about 7 hours before initial use.

9.2.1 Selecting a base unit

When "Auto" is selected, the cordless handset will automatically use any available base unit it is registered to. When a specific base unit is selected, the cordless handset will make and receive calls using that base unit only. If the cordless handset is out of range of that base unit, no calls can be made.

- 1 **[Υ]** → **[Υ]** → **OK**
- 2 "Select Base" → **OK**
- 3 Select the desired base unit number, or "Auto". → **OK**
 - The cordless handset starts searching for the base unit.

9.2.2 Cancelling a cordless handset

A maximum of 6 cordless handsets can be registered to a base unit. A cordless handset can cancel its own registration (or the registration of another cordless handset) that is stored in the base unit. This will allow the base unit to forget the cordless handset.

- 1 **[Υ]** → **[Υ]** → **OK**
- 2 Enter "335".
- 3 "Cancel Handset" → **OK**
 - The numbers of all cordless handsets registered to the base unit are displayed.
- 4 Select the cordless handset(s) you want to cancel, by pressing the desired cordless handset number. → **OK**
- 5 "Yes" → **OK** → **[Υ]**

9.2.3 Cancelling a base unit

A cordless handset can be registered to a maximum of 4 base units. A cordless handset can cancel a base unit that it is registered to. This allows the cordless handset to forget the base unit.

- 1 **[Υ]** → **[Υ]** → **OK**
- 2 "Registration" → **OK**
- 3 Enter "335".
- 4 "Cancel Base" → **OK**
- 5 Select the base unit(s) you want to cancel, by pressing the desired base unit number. → **OK**
- 6 "Yes" → **OK** → **[Υ]**

9. Multi-unit Operation

Note:

- To register the cordless handset to another base unit or to the same base unit again, see (page 59).



9.2.4 Increasing the range of the base unit

You can increase the signal range of the base unit by using a DECT repeater. Please use only Panasonic DECT repeater. See page 9 for accessory information.



Important:

- Before registering the repeater to this base unit, you must turn the repeater mode ON.
- Do not use more than one repeater at a time.

Setting the repeater mode

1.  →  → **OK**
2. "Other Options" → **OK**
3. "Repeater Mode" → **OK**
4. "On" or "off" → **OK** → **[*0]**

Note:

- After turning repeater mode ON or OFF,  may flash on the cordless handset momentarily. This is normal. The cordless handset can be used once  stops flashing.

9.3 Intercom

Intercom calls can be made between a cordless handset and the base unit, and between 2 cordless handsets. You can page all cordless handsets at once from the base unit.

9.3.1 Making intercom calls

With the cordless handset

- 1 **[INT]**
- 2 To page the base unit, press **[0]**.
To page another cordless handset, press the desired cordless handset number.
 - The base unit or the destination cordless handset will beep (be paged) for 1 minute.
 - To stop paging, press **[*0]**.
- 3 When the paged party answers, talk into the cordless handset.
- 4 To end the intercom call, press **[*0]**.

With the base unit

- 1 **[INTERCOM]**
- 2 To page one cordless handset, press the desired cordless handset number.
To page all cordless handsets, press **[0]**.
 - The destination cordless handset(s) will beep (be paged) for 1 minute.
 - To stop paging, press **[SP-PHONE]** or **[INTERCOM]**.
- 3 When the paged party answers, talk into **[MIC]**.

- 4 To end the intercom call, press **[SP-PHONE]**, **[INTERCOM]**.

Cordless handset locator

Using this feature, you can locate a cordless handset if it has been misplaced.

9.3.2 Answering intercom calls

With the cordless handset

When the cordless handset is being paged, it will beep (be paged) and the ringer indicator will flash rapidly. The display will show the paging extension's number.

- 1 Press **[📞]**, **[📞]** or **[INT]** to answer the page.
- 2 To end the intercom call, press **[*0]**.

With the base unit

When the base unit is being paged, it will beep and display the paging extension's number.

- 1 Press **[SP-PHONE]**, **[INTERCOM]** or lift the handset to answer the page.
- 2 To end the intercom call, press **[SP-PHONE]**, **[INTERCOM]** or replace the handset.

9.4 Transferring a call/conference

A telephone call can be transferred between a cordless handset and the base unit, and between 2 cordless handsets using the intercom feature.

9.4.1 To the base unit or another cordless handset (using the cordless handset)

- 1 **Cordless handset:**
During a phone call, press **[INT]**.
 - The call will be put on hold.
- 2 **Cordless handset:**
To page the base unit, press **[0]**.
To page another cordless handset, press the desired cordless handset number.
- 3 **Base unit:**
Press **[SP-PHONE]** or lift the handset to answer the page.
Another cordless handset:
Press **[📞]** or **[📞]** to answer the page.
- 4 **Cordless handset:**
To complete the transfer, press **[*0]**.
To establish a conference call, press **[3]**.

9.4.2 To a cordless handset (using the base unit)

- 1 **Base unit:**
During a phone call, press **[INTERCOM]**.
 - The call will be put on hold.

- 2 Base unit:**
To page one cordless handset, press the desired cordless handset number.
To page all cordless handsets, press **[0]**.
- 3 Cordless handset:**
 Press **[↶]** or **[↷]** to answer the page.
- 4 Base unit:**
 To complete the transfer, press **[SP-PHONE]** or replace the handset.
 To establish a conference call, press **[3]**.

Note:

- If the paged party does not answer the call, press **[↶]**, **[↷]** on the cordless handset, **[SP-PHONE]** on the base unit or lift the handset to return to the call.

9.5 Copying phonebook items

One or all phonebook items can be copied between a cordless handset and the base unit or between 2 cordless handsets. The destination unit will save the items in its phonebook.

9.5.1 To the base unit or another cordless handset (using the cordless handset)

Copying one phonebook item

1. Find the desired cordless handset phonebook item (page 25). → **[☰]**
2. "Copy" → **[OK]**
3. **To copy to the base unit**, press **[0]**.
To copy to another cordless handset, press the desired cordless handset number you wish to send the cordless handset phonebook item to.
 - When an item has been copied, "Completed" is displayed.
 - To continue copying another item:
 "Yes" → **[OK]** → Find the desired cordless handset phonebook item. → **[OK]**
4. **[↶⊙]**

Copying all the phonebook items

1. **[☰]** → **[☰]**
2. "Copy All" → **[OK]**
3. **To copy to the base unit**, press **[0]**.
To copy to another cordless handset, press the desired cordless handset number you wish to send the cordless handset phonebook item to.
 - When all items have been copied, "Completed" is displayed.
4. **[↶⊙]**

9.5.2 To the cordless handset (using the base unit)

Copying one phonebook item

1. **[MENU]** → **[⇄][5][9]**
2. Press **[1]** to display "1 ITEM". → **[SET]**
3. Enter the cordless handset number you wish to send the item to.
4. Press **[+]** or **[-]** repeatedly to display the desired item.
5. **[SET]**
 - To copy another item, repeat steps 4 and 5.
6. After copying is completed, press **[MENU]**

Copying all the phonebook items

1. **[MENU]** → **[⇄][5][9]**
2. Press **[2]** to display "ALL ITEMS". → **[SET]**
3. Enter the cordless handset number you wish to send the item to.

10.1 Character entry

The dial keys are used to enter characters and numbers. Each dial key has multiple characters assigned to it. The available character entry modes are Alphabet (ABC), Numeric (0-9), Greek (ΑΒΓ), Extended 1 (ÄÄÄ), Extended 2 (ŠŠŠ), and Cyrillic (АБВ). For SMS messages, Alphabet (ABC), Numeric (0-9), Greek (ΑΒΓ), and Extended (ÄÄÄ) modes are available. When in these entry modes except Numeric, you can select which character is entered by pressing a dial key repeatedly.

- Press [◀] or [▶] to move the cursor.
- Press dial keys to enter characters and numbers.
- Press [STOP] on the base unit or [C/⊗] on the cordless handset to erase the character or number highlighted by the cursor. Press and hold [STOP]/[C/⊗] to erase all characters or numbers.
- Press [*] to switch between uppercase and lowercase.
- To enter another character located on the same dial key, press [▶] to move the cursor to the next space, then press the appropriate dial key.

10.1.1 Character entry modes

Several character entry modes can be used when entering text. The characters that can be entered depend on the entry mode.

10.1.2 Characters available in each character entry mode

When the base unit displays the character entry screen:

Press [⏏] repeatedly to select a character entry mode.

When the cordless handset displays the character entry screen:

[1/2/3] → Select a character entry mode. → **OK**

Note:

- For character entry when writing SMS messages, see page 63.

Alphabet character table (ABC)

0	1	ABC 2	DEF 3	GHI 4	JKL 5	MNO 6	PQRS 7	TUV 8	WXYZ 9
Space 0	Space # & ' () * , - . / 1	A B C 2	D E F 3	G H I 4	J K L 5	M N O 6	P Q R S 7	T U V 8	W X Y Z 9
		a b c 2	d e f 3	g h i 4	j k l 5	m n o 6	p q r s 7	t u v 8	w x y z 9

Numeric entry table (0-9)

0	1	ABC 2	DEF 3	GHI 4	JKL 5	MNO 6	PQRS 7	TUV 8	WXYZ 9
0	1	2	3	4	5	6	7	8	9

Greek character table (ΑΒΓ)

0	1	ABC 2	DEF 3	GHI 4	JKL 5	MNO 6	PQRS 7	TUV 8	WXYZ 9
Space 0	Space # & ' () * , - . / 1	A B Γ 2	Δ E Z 3	H Θ I 4	K Λ M 5	N Ξ O 6	Π Ρ Σ 7	T Υ Φ 8	X Ψ Ω Ξ 9

Extended 1 character table (ÄÄÄ)

0	1	ABC 2	DEF 3	GHI 4	JKL 5	MNO 6	PQRS 7	TUV 8	WXYZ 9
Space 0	Space # & ' () * , - . / 1	A Ä Ä Ä Ä Ä Ä Æ B C Ç 2	D E È É È È Ë F 3	G Ğ H I Ì Ì Ï Ì Ì 4	J K L 5	M N Ñ O Ó Ó Ô Ö Ö ø 6	P Q R S Ş B 7	T U Ü Ú Û Ü Û V 8	W Ŵ X Y ŷ Z 9
		a à á â ä å à æ b c ç 2	d e è é ê ë ë f 3	g ğ h i ì ì ï ì ì 4	j k l 5	m n ñ o ó ó ô ö ö ø 6	p q r s ş B 7	t u ü ú û ü û v 8	w ŵ x y ŷ z 9

- The following are used for both uppercase and lowercase: ø Ş Ŵ ŷ

Extended 2 character table (SŠŠ)

0	1	ABC 2	DEF 3	GHI 4	JKL 5	MNO 6	PQRS 7	TUV 8	WXYZ 9
Space 0	Space # & ' () * , - . / 1	A Á Â À B C Ĉ Ć 2	D Ď E É Ê Ë F 3	G H I í 4	J K L Ĺ Ľ Ľ 5	M N Ń Ň O Ó ô ö 6	P Q R Ŕ Ř S Š Š 7	T ť U Ú Ů Ů ú v 8	W X Y ŷ Ý Ž Ž Ž Ž 9
		a á â À b c Ĉ Ć 2	d ě e é ê ë f 3	g h i í 4	j k l Ĺ Ľ 5	m n Ń ň o ó ô ö 6	p q r Ŕ ř s š š 7	t ť u ú Ů Ů ú v 8	w x y ŷ ý ž ž ž ž 9

- The following are used for both uppercase and lowercase:

Ą Ć Ć Ę ĺ Ĺ Ĺ Ń Ŕ Š Š ů ŷ Ž Ž Ž

Cyrillic character table (АБВ)

0	1	ABC 2	DEF 3	GHI 4	JKL 5	MNO 6	PQRS 7	TUV 8	WXYZ 9
Space 0	Space # & ' () * , - . / 1	А Б В	Д Е Ж	И Й К	М Н О	Р С Т	Ф Х Ц	Ш Щ	Ъ Э Ю
0	Г	3	Л	П	У	Ч	Ъ Ы	Я	9
ĩ ŷ	2	3	4	5	6	7	8	9	

10.1.3 When writing SMS messages

Alphabet character table (ABC)

0	1	ABC 2	DEF 3	GHI 4	JKL 5	MNO 6	PQRS 7	TUV 8	WXYZ 9
Space 0	Space . @ / : ; * # + - 1 " ' , ! i ?	A B C	D E F	G H I	J K L	M N O	P Q R S	T U V	W X Y Z
	ĩ - € £ \$ ¥ () [] { } & % \ ^ ~ < > = □ §	a b c	d e f	g h i	j k l	m n o	p q r s	t u v	w x y z
		2	3	4	5	6	7	8	9

Numeric entry table (0-9)

0	1	ABC 2	DEF 3	GHI 4	JKL 5	MNO 6	PQRS 7	TUV 8	WXYZ 9
0	1	2	3	4	5	6	7	8	9

Greek character table (ΑΒΓ)

0	1	ABC 2	DEF 3	GHI 4	JKL 5	MNO 6	PQRS 7	TUV 8	WXYZ 9
Space 0	Space . @ / : ; * # + - 1 " ' , ! i ?	Α Β Γ	Δ Ε Ζ	Η Θ Ι	Κ Λ Μ	Ν Ξ Ο	Π Ρ Σ	Τ Υ Φ	Χ Ψ Ω
	ĩ - € £ \$ ¥ () [] { } & % \ ^ ~ < > = □ §	2	3	4	5	6	7	8	9

Extended character table (AĂĂ)

0	1	ABC 2	DEF 3	GHI 4	JKL 5	MNO 6	PQRS 7	TUV 8	WXYZ 9
Space 0	Space . @ / : ; * # + - 1 " ' , ! i ?	A Ă Á À Ā Ā Ă Ą B	D E Ę É Ê Ë Ĕ ĕ F 3	G Ğ Ğ H Ĩ Ĩ ı ĩ ĩ 4	J K L	M N Ń Ň Ő Ó ô ö 6	P Q R S Ş ß 7	T U Ů Ú Ů Ů ú v 8	W X Y Z 9
	ĩ - € £ \$ ¥ () [] { } & % \ ^ ~ < > = □ §	a à á â ä å ă ă b c ç 2	d e è é ê ë ĕ ě f 3	g ğ Ğ h Ĩ Ĩ ı ĩ ĩ 4	j k l 5	m n ñ ň Ő ó ô ö 6	p q r s Ş ß 7	t u Ů ú Ů Ů ú v 8	w x y z 9

- The following are used for both uppercase and lowercase: ø Š

11.1 Error messages – Reports

If a problem occurs during fax transmission or reception, one of the following messages will be printed on the sending and journal reports (page 35).

Message	Code	Cause & Solution
COMMUNICATION ERROR	40-42 46-72 FF	<ul style="list-style-type: none"> • A transmission or reception error occurred. Try again or check with the other party.
	43 44	<ul style="list-style-type: none"> • A line problem occurred. Connect the telephone line cord to a different socket and try again. • An overseas transmission error occurred. Try using the overseas mode (feature #23 on page 51).
DOCUMENT JAMMED	-----	<ul style="list-style-type: none"> • Remove the jammed document (page 75).
ERROR-NOT YOUR UNIT	53 54 59 70	<ul style="list-style-type: none"> • A transmission or reception error occurred because of a problem with the other party's fax machine. Check with the other party.
JUNK FAX PROH. REJECT	-----	<ul style="list-style-type: none"> • The junk fax prohibitor feature of this unit rejected fax reception.
MEMORY FULL	-----	<ul style="list-style-type: none"> • The memory is full of received documents due to a lack of recording paper, a lack of ink film or a recording paper jam. Install paper (page 16), install ink film (page 14) or remove the jammed paper (page 74).
NO DOCUMENT	-----	<ul style="list-style-type: none"> • The document was not fed into the unit properly. Re-insert the document and try again.
OTHER FAX NOT RESPONDING	-----	<ul style="list-style-type: none"> • The other party's fax machine is busy or has run out of recording paper. Try again. • The other party's fax machine rang too many times. Send the fax manually (page 35). • The other party's machine is not a fax machine. Check with the other party. • The number you dialled is not in service.
PRESSED THE STOP KEY	-----	<ul style="list-style-type: none"> • [STOP] was pressed, and fax transmission or reception was cancelled.
OK	-----	<ul style="list-style-type: none"> • Fax transmission or reception was successful.

11.2 Error messages – Display

If the unit detects a problem, one or more of the following messages will appear on the display.

11.2.1 Base unit

Display	Cause & Solution
“BACK COVER OPEN”	<ul style="list-style-type: none"> • The back cover is open. Close the back cover firmly.
“BUSY”	<ul style="list-style-type: none"> • The cordless handset you tried to call is in use. • The cordless handset you are calling is too far from the base unit.
“CALL SERVICE”	<ul style="list-style-type: none"> • There is something wrong with the unit. Contact our service personnel.
“CHECK DOCUMENT”	<ul style="list-style-type: none"> • The document was not fed into the unit properly. Re-insert the document. If misfeeding occurs frequently, clean the document feeder rollers (page 76) and try again. • The document is longer than 600 mm. Press [STOP] to remove the document. Divide the document into two or more sheets, and try again.
“CHECK FILM”	<ul style="list-style-type: none"> • The ink film is empty. Replace the ink film with a new one (page 14). • The ink film is not installed. Install it (page 14). • The ink film is slack or creased. Tighten it (see step 5 on page 14).
“CHECK MEMORY”	<ul style="list-style-type: none"> • The base unit memory (telephone numbers, parameters, etc.) has been erased. Re-program.
“CHECK PAPER”	<ul style="list-style-type: none"> • The recording paper is not installed or the unit has run out of paper. Install paper and press [SET] to clear the message. • The recording paper was not fed into the unit properly (page 75). Re-install paper (page 16) and press [SET] to clear the message. • The recording paper has jammed near the recording paper entrance. Remove the jammed paper (page 74) and press [SET] to clear the message.
“FAX IN MEMORY”	<ul style="list-style-type: none"> • See the other displayed message instructions to print out the document. Received documents are stored in memory due to a lack of recording paper, a lack of ink film or a recording paper jam. Install paper (page 16), install ink film (page 14) or remove the jammed paper (page 74). You will lose all faxes in memory if the power is removed. Check with power connected.
“FAX MEMORY FULL”	<ul style="list-style-type: none"> • The memory is full of received documents due to a lack of recording paper, a lack of ink film or a recording paper jam. Install paper (page 16), install ink film (page 14) or remove the jammed paper (page 74). You will lose all faxes in memory if the power is removed. Check with power connected. • When performing memory transmission, the document being stored exceeded the memory capacity of the unit. Send the entire document manually.
“FILM EMPTY”	<ul style="list-style-type: none"> • The ink film is empty. Replace the ink film with a new one (page 14). • The ink film is slack. Tighten it (see step 5 on page 14) and install again. • The fax machine is positioned near appliances such as TVs or speakers which generate an intense magnetic field.
“FILM NEAR EMPTY”	<ul style="list-style-type: none"> • The remaining ink film is low. Prepare a new ink film (page 9).
“MEMORY FULL”	<ul style="list-style-type: none"> • The base unit’s phonebook memory is full. Erase unnecessary items (page 27). • When making a copy, the document being stored exceeded the memory capacity of the unit. Press [STOP] to clear the message. Divide the document into sections.

11. Help

Display	Cause & Solution
"MESSAGE FULL"	<ul style="list-style-type: none">● There is no room left in memory to record voice messages. Erase unnecessary messages (page 46, 47).
"MODEM ERROR"	<ul style="list-style-type: none">● There is something wrong with the unit's modem. Contact our service personnel.
"NO FAX REPLY"	<ul style="list-style-type: none">● The other party's fax machine is busy or has run out of recording paper. Try again.
"OPEN CABINET CHECK FILM SLACK" "OPEN CABINET CHECK FILM TYPE"	<ul style="list-style-type: none">● Please use genuine Panasonic replacement film (page 9).● The ink film is slack. Tighten it (see step 5 on page 14).● The fax machine is positioned near appliances such as TVs or speakers which generate an intense magnetic field.
"PAPER JAMMED"	<ul style="list-style-type: none">● A recording paper jam occurred. Remove the jammed paper (page 74).● You forced the recording paper into the paper tray too strongly. Remove all of the installed paper, and re-install it gently.
"PLEASE WAIT"	<ul style="list-style-type: none">● The unit is checking that there is no slack or crease in the ink film. Wait for a moment while the check is completed.
"POLLING ERROR"	<ul style="list-style-type: none">● The other party's fax machine does not support polling. Check with the other party.
"RECORDING ERROR"	<ul style="list-style-type: none">● The greeting message you recorded was under 1 second long. Record a longer message.
"REDIAL TIME OUT"	<ul style="list-style-type: none">● The other party's fax machine is busy or has run out of recording paper. Try again.
"REMOVE DOCUMENT"	<ul style="list-style-type: none">● The document is jammed. Remove the jammed document (page 75).● Press [STOP] to eject the jammed paper.
"SERIAL ERROR"	<ul style="list-style-type: none">● There is something wrong with the unit and the base unit will not work. Contact our service personnel.
"TRANSMIT ERROR"	<ul style="list-style-type: none">● A transmission error occurred. Try again.● If you send a fax overseas, try the following:<ul style="list-style-type: none">– Make sure the other party's number is a fax number.– Use the overseas transmission mode (feature #23 on page 51).– Add 2 pauses at the end of the telephone number or dial manually.
"UNIT OVERHEATED"	<ul style="list-style-type: none">● The unit is too hot. Stop using the unit for a while and let the unit cool down.

11.2.2 Cordless handset

Display	Cause & Solution
"Answer Sys. Full"	<ul style="list-style-type: none">● Erase unnecessary messages (page 46, 47).
"Error"	<ul style="list-style-type: none">● Recording was too short. Try again.
"Failed"	<ul style="list-style-type: none">● Phonebook copy failed. Confirm the destination unit is in standby mode and try again.
"Incomplete"	<ul style="list-style-type: none">● The destination unit's phonebook memory is full. Erase the unnecessary phonebook items from the destination unit and try again.
"Invalid Number"	<ul style="list-style-type: none">● You tried to send an SMS message to a phone number saved in the base unit phonebook, cordless handset phonebook, Caller ID list, or redial list that is over 20 digits long.

Display	Cause & Solution
"Memory Full"	<ul style="list-style-type: none"> • The cordless handset's phonebook memory is full. Erase unnecessary items (page 26). • There is no room left in memory to record voice messages. Erase unnecessary messages (page 46, 47).
"SMS Full"	<ul style="list-style-type: none"> • Erase unnecessary messages (page 33).
"You must first subscribe to Caller ID."	<ul style="list-style-type: none"> • You must subscribe to Caller ID service. Once you receive caller information after subscribing to Caller ID service, this message will not be displayed.

11.3 When a function does not work, check here

If you still have difficulties after following the instructions in this section, reset the unit. Disconnect the power cord and turn OFF the cordless handset. Reconnect the power cord and turn ON the cordless handset.

11.3.1 Initial settings

Problem	Cause & Solution
I cannot hear a dial tone.	<ul style="list-style-type: none"> • If you used a splitter/coupler to connect the unit, remove the splitter/coupler and connect the unit to the wall jack directly. If the unit operates properly, check the splitter/coupler. • Disconnect the unit from the telephone line and connect a known working telephone. If the working telephone operates properly, contact our service personnel to have the unit repaired. If the working telephone does not operate properly, contact your telephone company. • The power cord or telephone line cord is not connected. Check the connections. • If you have connected the fax machine through a computer modem, connect the fax machine directly to a telephone line jack.
The unit does not work.	<ul style="list-style-type: none"> • Make sure that the cordless handset's battery is installed correctly (page 16) and fully charge it (page 18). • Check the connections (page 17).
The unit does not ring.	<ul style="list-style-type: none"> • The night mode feature is turned ON. Turn it OFF (page 24). • The ringer volume is turned OFF. Adjust it (page 19).
I cannot make calls.	<ul style="list-style-type: none"> • You dialed a call restricted number. Remove the number from the call restricted list (page 58).

11.3.2 General

Problem	Cause & Solution
The unit displays "PAPER JAMMED" even though paper is installed.	<ul style="list-style-type: none"> • You forced the recording paper into the paper tray too strongly. Remove all of the installed paper, and re-install it gently.
The unit displays "CHECK PAPER" even though paper is inserted.	<ul style="list-style-type: none"> • The paper is inserted halfway. Insert it correctly (page 75) and press [SET] to clear the message.
The other party complains they only hear a fax tone and cannot talk.	<ul style="list-style-type: none"> • FAX ONLY mode is set. Tell the other party the number is only used for faxes. • Change the receiving mode to TEL mode (page 39) or TAM/FAX mode (page 40).

11. Help

Problem	Cause & Solution
[REDIAL] or [PAUSE] on the base unit does not function properly.	<ul style="list-style-type: none">● If this button is pressed during dialling, a pause will be inserted. If pressed immediately after a dial tone is obtained, the last number dialled will be redialled.
The receiving mode does not function properly.	<ul style="list-style-type: none">● The Distinctive Ring is set (feature #31 on page 52).
During programming, I cannot enter the code or ID number.	<ul style="list-style-type: none">● All or part of the number is the same as another code or ID. Change the number:<ul style="list-style-type: none">– remote operation ID (code): page 48, or feature #11 on page 51.– fax activation code: feature #41 on page 53.– auto disconnection code: feature #49 on page 54.
The ink film runs out quickly.	<ul style="list-style-type: none">● Even if there are only a few sentences, every page that comes out of the machine is considered a full page.● Turn OFF the following features:<ul style="list-style-type: none">– sending report: feature #04 on page 50.– journal report: feature #22 on page 51.– Caller ID list: feature #26 on page 52.
The base unit beeps.	<ul style="list-style-type: none">● The memory reception alert of feature #44 is ON (page 53), and the unit has a document in memory. Press [STOP] to stop the beeps, then see the displayed message instructions to solve the problem.
The speakerphone is not working.	<ul style="list-style-type: none">● Use the speakerphone in a quiet room.● If you have difficulty hearing the other party, adjust the volume.
I cannot page a cordless handset or base unit.	<ul style="list-style-type: none">● The cordless handset is too far from the base unit.
The unit does not display the caller's name and/or telephone number.	<ul style="list-style-type: none">● You need to subscribe to a Caller ID service.● Other telephone equipment may be interfering with your phone. Disconnect it and try again.● Other electrical appliances connected to the same outlet may be interfering with the Caller ID information.● Telephone line noise may be affecting the Caller ID information.● The caller requested not to send his/her information (page 28).● If a call is being transferred to you, the caller information will not be displayed.
The display exits the Caller ID List while viewing caller information.	<ul style="list-style-type: none">● Do not pause for over 1 minute on the cordless handset or 3 minutes on the base unit while viewing.

11.3.3 Cordless handset

Problem	Cause & Solution
The cordless handset does not work.	<ul style="list-style-type: none">● Make sure that the battery is installed correctly (page 16) and fully charge it (page 18).● Clean the charge contacts and charge again (page 18).● Turn the cordless handset power OFF, then ON (page 18).● Check that the power cord is connected properly.● The cordless handset has not been registered to the base unit. Register the cordless handset (page 59).● Re-install the batteries (page 16) and fully charge them.
The cordless handset display is blank.	<ul style="list-style-type: none">● The cordless handset is in screen saver mode (page 18). Press [*0] to activate the cordless handset display again.● The cordless handset is not turned ON. Turn the power ON (page 18).

Problem	Cause & Solution
The cordless handset will not turn ON.	<ul style="list-style-type: none"> ● Make sure that the batteries are installed correctly (page 16). ● Fully charge the batteries (page 18). ● Clean the charge contacts and charge again (page 18).
I have changed the cordless handset display language to a language I cannot read.	<ul style="list-style-type: none"> ● Change the cordless handset display language (page 58).
Y is flashing.	<ul style="list-style-type: none"> ● The cordless handset is not registered to the base unit. Register it (page 59). ● The cordless handset is too far from the base unit. Move closer. ● The power cord is not connected. Check the connections.
The cordless handset does not ring.	<ul style="list-style-type: none"> ● The night mode feature is turned ON. Turn it OFF (page 24). ● The ringer volume is turned OFF. Adjust it (page 19).
The batteries should be charging but the battery icon does not change.	<ul style="list-style-type: none"> ● Clean the charge contacts and charge again (page 18).
A busy tone is heard when [↶] is pressed.	<ul style="list-style-type: none"> ● The cordless handset is too far from the base unit. Move closer and try again. ● The base unit or another cordless handset is on an outside call. Wait for the other user to complete the call.
Static, sound cuts in/out, fades. Interference from other electrical units.	<ul style="list-style-type: none"> ● Place the cordless handset and the base unit away from other electrical appliances. ● Move closer to the base unit.
Noise is heard during a call.	<ul style="list-style-type: none"> ● You are using the handset or base unit in an area with high electrical interference. Place the handset and base unit away from interference sources, such as antennas and mobile phones.
The cordless handset stops working while being used.	<ul style="list-style-type: none"> ● Disconnect the power cord and turn OFF the cordless handset to reset the unit. Connect the power cord, turn ON the cordless handset and try again.
I assigned a phonebook item to a desired category, but category ringtones will not sound.	<ul style="list-style-type: none"> ● You must subscribe to Caller ID service. ● Set to TEL mode, TAM/FAX mode or FAX ONLY mode to use SMS features.
I cannot redial by pressing [●].	<ul style="list-style-type: none"> ● If the redialled number was more than 24 digits long, the number will not be redialled. Redial the number manually.
Mute does not turn off after the line is connected.	<ul style="list-style-type: none"> ● Press [C/⊗].
[] flashes or the cordless handset beeps intermittently while it is in use.	<ul style="list-style-type: none"> ● Fully charge the batteries (page 18).
I fully charged the batteries, but [] still flashes.	<ul style="list-style-type: none"> ● Clean the charge contacts and charge again (page 18). ● It is time to replace the batteries (page 16).
I cannot make calls with the cordless handset.	<ul style="list-style-type: none"> ● You dialled a call restricted number. Remove the number from the call restricted list (page 58). ● The key lock feature is turned ON. Turn it OFF (page 22).

11. Help

Problem	Cause & Solution
I cannot register a cordless handset to a base unit.	<ul style="list-style-type: none">• The maximum number of base units are already registered to the cordless handset. Cancel unused base unit registrations from the cordless handset (page 59).• The maximum number of cordless handsets are already registered to the base unit. Cancel unused cordless handset registrations from the base unit (page 59).• You entered the wrong PIN. If you forget your PIN, consult your nearest Panasonic service centre.• Place the cordless handset and the base unit away from other electrical appliances.

11.3.4 Fax – sending



Problem	Cause & Solution
I cannot send documents.	<ul style="list-style-type: none">• The other party's fax machine is busy or has run out of recording paper. Try again.• The other party's machine is not a fax machine. Check with the other party.• The other party's fax machine failed to answer the fax automatically. Send the fax manually (page 35).• The memory is full of received documents and the quick scan (feature #34 on page 52) is ON. Turn this feature OFF, and send the fax again.
I cannot send a fax overseas.	<ul style="list-style-type: none">• Use the overseas transmission mode (feature #23 on page 51).• Add two pauses at the end of the telephone number or dial manually.
The other party complains that letters on their received document are distorted or not clear.	<ul style="list-style-type: none">• If your line has special telephone services such as call waiting, the service may have been activated during fax transmission. Connect the unit to a line that does not have these services.• Another telephone on the same line is off the hook. Hang up the telephone and try again.• Try copying the document with this unit. If the copied image is clear, there may be something wrong with the other party's machine.• Adjust the scan contrast using feature #58 (page 54).
The other party complains that black lines, white lines or smudges appear on their received document.	<ul style="list-style-type: none">• The scanner glass or rollers are dirty with correction fluid, etc. Clean them (page 76). Please do not insert a document before correction fluid has dried completely.
Documents frequently misfeed.	<ul style="list-style-type: none">• Clean the document feeder rollers, recording paper feeder and rubber flap (page 76).

11.3.5 Fax – receiving

Problem	Cause & Solution
I cannot receive documents.	<ul style="list-style-type: none">• The ink film is empty. Replace the ink film with a new one (page 14).
I cannot receive documents automatically.	<ul style="list-style-type: none">• The receiving mode is set to TEL mode. Change the receiving mode:<ul style="list-style-type: none">– TAM/FAX mode (page 40) or FAX ONLY mode (page 40).• The time taken to answer the call is too long. Decrease the number of rings (page 48, feature #06 on page 50).• The greeting message is too long. Record a shorter message (page 45).
The display shows "CONNECTING", but faxes are not received.	<ul style="list-style-type: none">• The receiving mode is set to FAX ONLY mode and the incoming call is not a fax. Change the receiving mode:<ul style="list-style-type: none">– TAM/FAX mode (page 40) or TEL mode (page 39).

Problem	Cause & Solution
A blank sheet is ejected.	<ul style="list-style-type: none"> ● If a blank sheet is ejected after the received document is printed out, the size of the document sent by the other party is as large as, or larger than, the recording paper, and the receiving reduction rate is not programmed correctly. Program the proper rate in feature #36 (page 53). ● The other party placed the document in their fax machine facing the wrong way. Check with the other party.
The printing quality is poor.	<p>Please do not reuse the ink film! Please use genuine Panasonic replacement film. Refer to page 9 for further details.</p> <ul style="list-style-type: none"> ● The thermal head is dirty. Clean it (page 77). ● If documents can be copied properly, the unit is working normally. The other party may have sent a faint document or there may be something wrong with the other party's machine. Ask them to send a clearer copy of the document or to check their fax machine. ● Some paper has instructions recommending which side to print on. Try turning the recording paper over. ● You may have used paper with cotton and/or fibre content that is over 20%, such as letterhead or resume paper.
Recording paper frequently misfeeds.	<ul style="list-style-type: none"> ● Clean the document feeder rollers, recording paper feeder and rubber flap (page 76).
Letters on the received document are distorted.	<ul style="list-style-type: none"> ● If your line has special telephone services such as call waiting, the service may have been activated during fax reception. Connect the unit to a line that does not have these services.
I cannot receive documents using the cordless handset.	<ul style="list-style-type: none"> ● The memory is full of received documents due to a lack of recording paper, a lack of ink film or a recording paper jam. Install paper (page 16), install ink film (page 14) or remove the jammed paper (page 74).
When an extension telephone is connected, I cannot receive documents by pressing [*][#][9].	<ul style="list-style-type: none"> ● You must set remote fax activation to ON (feature #41 on page 53) beforehand. ● You may have changed the remote fax activation code from [*][#][9] (default setting). Verify the remote fax activation code (feature #41 on page 53). ● The memory is full of received documents due to a lack of recording paper, a lack of ink film or a recording paper jam. Install paper (page 16), install ink film (page 14) or remove the jammed paper (page 74).
The other party complains that they cannot send a document.	<ul style="list-style-type: none"> ● The receiving mode is set to TEL mode. Receive the document manually (page 39) or change the receiving mode to TAM/FAX mode (page 40) or FAX ONLY mode (page 40). ● The memory is full of received documents due to a lack of recording paper, a lack of ink film or a recording paper jam. Install paper (page 16), install ink film (page 14) or remove the jammed paper (page 74).
I cannot select the desired receiving mode.	<ul style="list-style-type: none"> ● If you want to set TAM/FAX or FAX ONLY mode: <ul style="list-style-type: none"> – select the desired mode using feature #77 (page 55), and press [AUTO ANSWER] repeatedly until the desired mode is displayed. ● If you want to set TEL mode: <ul style="list-style-type: none"> – press [AUTO ANSWER] repeatedly to select TEL mode. – The Distinctive Ring is set (feature #31 on page 52).

11.3.6 Copying

Problem	Cause & Solution
The unit will not make a copy.	<ul style="list-style-type: none"> • The ink film is empty. Replace the ink film with a new one (page 14). • You cannot make a copy during programming. • You cannot make a copy during a telephone conversation.
A black line, white line or smudge appears on the copied document.	<ul style="list-style-type: none"> • The scanner glass or rollers are dirty with correction fluid, etc. Clean them (page 76). Please do not insert a document before correction fluid has dried completely.
The copied image is distorted.	<ul style="list-style-type: none"> • Adjust the width of the document guides to fit the actual size of the document.
The printing quality is poor. Original  Copy 	Please do not reuse the ink film! Please use genuine Panasonic replacement film. Refer to page 9 for further details. <ul style="list-style-type: none"> • The thermal head is dirty. Clean it (page 77). • Some paper has instructions recommending which side to print on. Try turning the recording paper over. • You may have used paper with a cotton and/or fibre content that is over 20%, such as letterhead or resume paper.
Documents or recording paper frequently misfeed.	<ul style="list-style-type: none"> • Clean the document feeder rollers, recording paper feeder and rubber flap (page 76).

11.3.7 Answering machine

Problem	Cause & Solution
I cannot listen to messages from a remote location.	<ul style="list-style-type: none"> • Activate the remote operation feature by setting the remote operation ID beforehand (page 48, feature #11 on page 51). Press the remote operation ID correctly and firmly. • The unit is not in TAM/FAX mode. Change to TAM/FAX mode (page 49).
The other party complains that they cannot leave a voice message.	<ul style="list-style-type: none"> • The recording time is set to "GREETING ONLY". Select "1 MINUTE" or "3 MINUTES" (page 48, feature #10 on page 51). • The memory is full. Erase unnecessary messages (page 46, 47). • Make sure there is no other answering machine connected on the same line.
I cannot operate the answering machine with the cordless handset.	<ul style="list-style-type: none"> • Someone is operating the answering machine. • You are too far from the base unit. Move closer to the base unit.
The message indicator flashes slowly.	<ul style="list-style-type: none"> • This is normal. New messages have been recorded. Listen to the new messages (page 46) or turn the message alert OFF (page 56).
Caller ID information does not display during message playback.	<ul style="list-style-type: none"> • The caller information will not be displayed if a message is recorded by using [MEMO] (page 46).

11.3.8 SMS

Problem	Cause & Solution
I cannot send or receive SMS messages.	<ul style="list-style-type: none"> ● You have not subscribed to the appropriate service. Consult your service provider. ● The SMS message centre number(s) are not stored or are incorrect. Store the correct numbers (page 32). ● Message transmission was interrupted. Wait until the message has been sent before using other telephone functions.
The SMS message centre number is logged in the caller list and the message is not received.	<ul style="list-style-type: none"> ● Someone tried to send you a message while SMS is turned OFF.
“FD” is displayed.	<ul style="list-style-type: none"> ● The unit could not connect to the SMS message centre. Confirm that the correct SMS message centre numbers are stored (page 32). Confirm that SMS is turned ON (page 31).
“FE” is displayed.	<ul style="list-style-type: none"> ● An error occurred while sending the message. Try again.
“E0” is displayed.	<ul style="list-style-type: none"> ● Your telephone number is permanently withheld or you have not subscribed to the appropriate service. Consult your service provider.
✓ is not displayed after you display a message. An error code is displayed.	<ul style="list-style-type: none"> ● When an error code (“FD”, “FE”, or “E0”) is displayed, ✓ will not be displayed even if you have displayed the message.

11.3.9 If a power failure occurs

- The unit will not function.
- The unit is not designed for making emergency telephone calls when the power fails. Alternative arrangements should be made for access to emergency services.
- Fax transmission and reception will be interrupted.
- If delayed transmission (feature #25 on page 52) is programmed and a power failure prevents the document from being sent at the set time, the document will be sent after power is restored.
- If any fax documents are stored in the memory, they will be lost. When power is restored, a power down report will be printed stating which documents in memory have been erased.

- Panasonic Australia operates a toll free Customer Care Centre. Please visit the website for assistance at <http://www.panasonic.com.au> or please call 132600.

12.1 Recording paper jams

12.1.1 When the recording paper has jammed in the unit

The display will show the following.

PAPER JAMMED

Important:

- Remove the recording paper, then remove the paper tray beforehand, otherwise the paper may misfeed or jam.

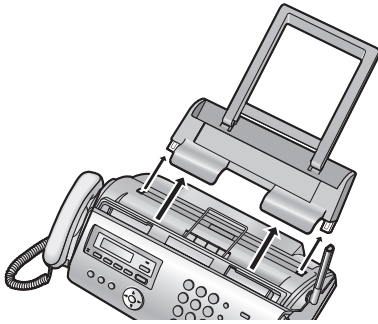

- 1 Open the front cover (①), push the green button (②), then open the back cover (③).

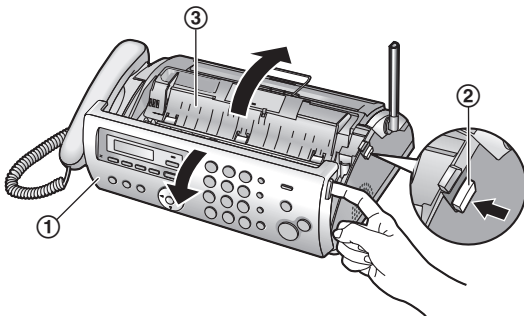

- 2 Remove the jammed recording paper (④).

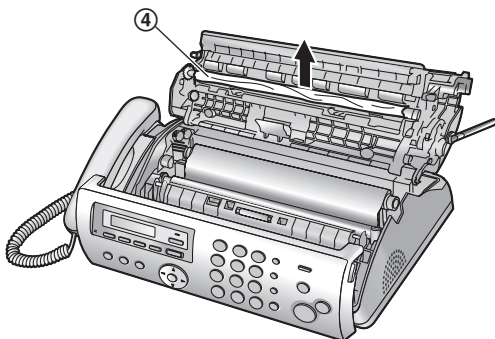

- 3 Turn the blue gear (⑤) in the direction of the arrow until the ink film is tight (⑥) and at least one layer of ink film is wrapped around the blue core (⑦).

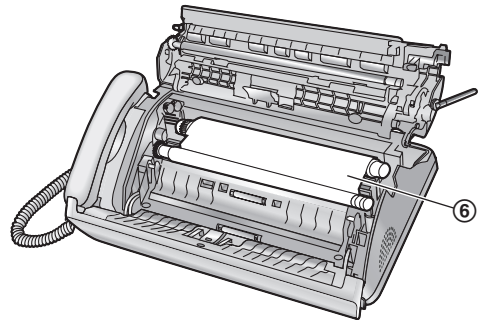
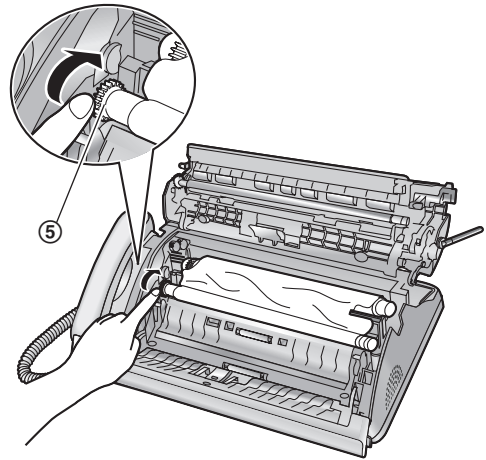

Correct

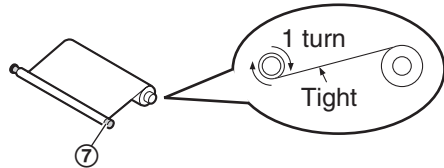

Incorrect

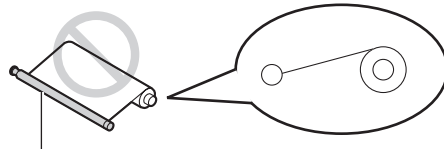

- 4 Close the back cover securely by pushing down on the dotted area at both ends (⑧), then close the front cover securely (⑨).

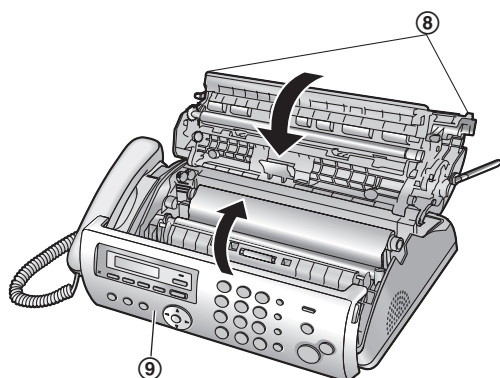

- 5 Install the paper tray (page 15), then insert the recording paper gently (page 16).

12.1.2 When the recording paper was not fed into the unit properly

The display will show the following.

CHECK PAPER

Remove the recording paper and straighten. Insert the paper, then press **[SET]** to clear the message.



12.2 Document jams

- 1 Open the front cover. Remove the jammed document carefully (①).

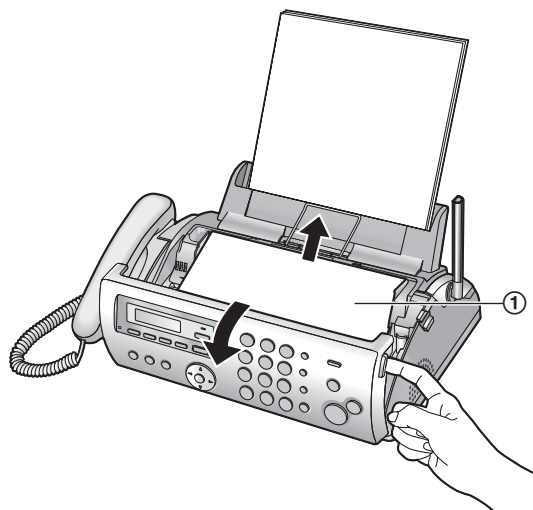

- 2 Close the front cover securely.

Note:

- Do not pull out the jammed paper forcibly before opening the front cover.

12.3 Document feeder/recording paper feeder/scanner glass cleaning

Clean the document feeder/recording paper feeder/scanner glass when:

- Documents or recording paper frequently misfeed.
- Smudges or black/white lines appear on the original document when sending or copying.

Important:

- Remove the recording paper, then remove the paper tray beforehand, otherwise the paper may misfeed or jam.

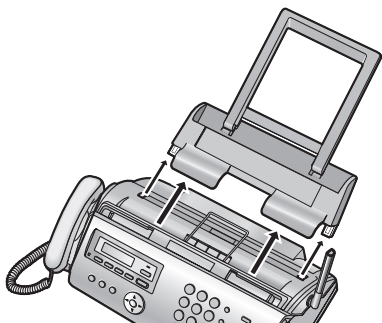

- 1 Disconnect the power cord and the telephone line cord.
- 2 Open the front cover (1), push the green button (2), then open the back cover (3).

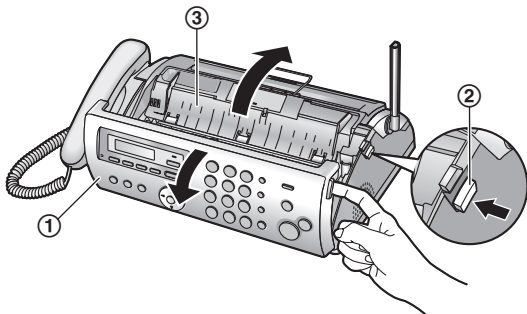

- 3 Clean the document feeder rollers (4) and rubber flap (5) with a cloth moistened with isopropyl rubbing alcohol, and let all parts dry thoroughly. Clean the scanner glass (6) with a soft, dry cloth.

Caution:

- Do not use paper products, such as paper towels or tissues.

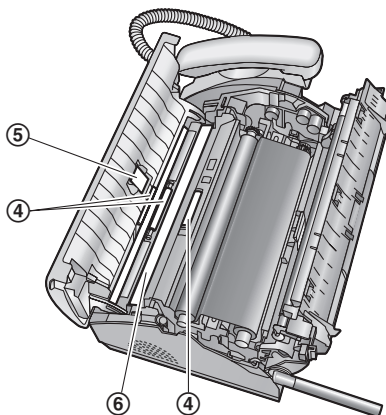

- 4 Clean the recording paper feeder roller (7) with a cloth moistened with isopropyl rubbing alcohol, and let all parts dry thoroughly.

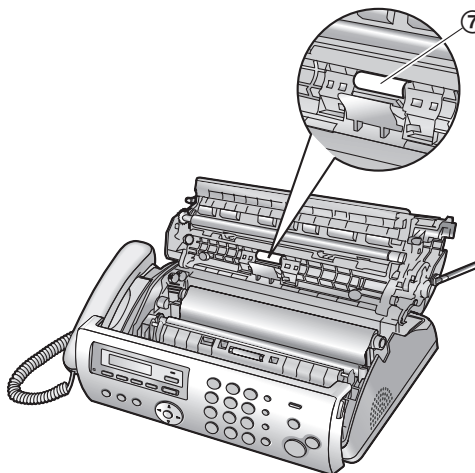

- 5 Close the back cover securely by pushing down on the dotted area at both ends (8), then close the front cover securely (9).

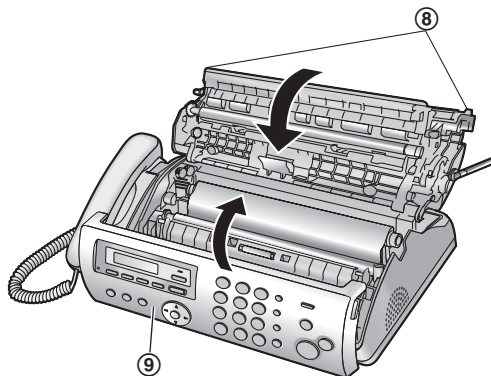

- 6 Install the paper tray (page 15), then insert the recording paper gently (page 16).
- 7 Connect the power cord and the telephone line cord.

12.4 Thermal head cleaning

If smudges or black/white lines appear on a copied/received document, check whether there is dust on the thermal head. Clean the thermal head to remove the dust.

Important:

- Remove the recording paper, then remove the paper tray beforehand, otherwise the paper may misfeed or jam.

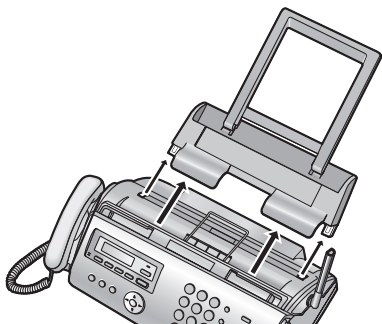

- 1 Disconnect the power cord and the telephone line cord.
- 2 Open the front cover (①), push the green button (②), then open the back cover (③).

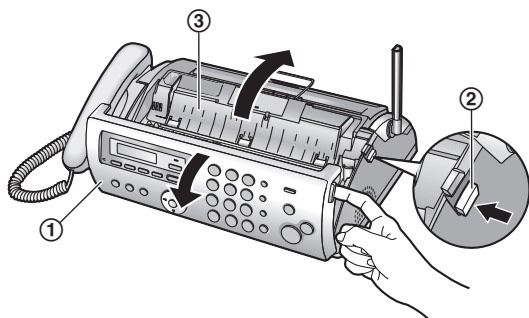

- 3 Remove the ink film (④).

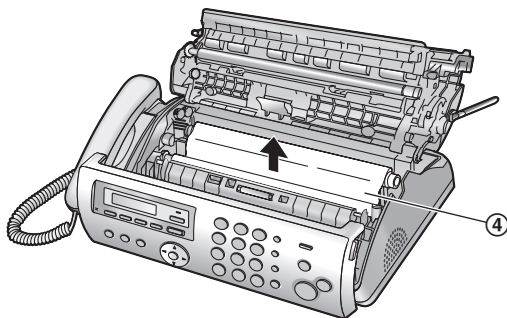

- 4 Clean the thermal head (⑤) with a cloth moistened with isopropyl rubbing alcohol, and let it dry thoroughly.

Caution:

- To prevent a malfunction due to static electricity, do not use a dry cloth and do not touch the thermal head directly.

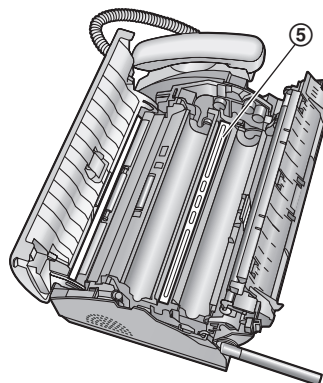

- 5 Re-install the ink film and close the covers (see step 4 to 7 on page 14).
- 6 Install the paper tray (page 15), then insert the recording paper gently (page 16).
- 7 Connect the power cord and the telephone line cord.

13.1 Reference lists and reports (Base unit only)

You can print out the following lists and reports for your reference:

- "SETUP LIST"
- "PHONEBOOK LIST"
- "JOURNAL REPORT"
- "BROADCAST LIST"
- "PRINTER TEST"
 - If the test print has a smudges, blurred points or lines, clean the thermal head (page 77).
- "CALLER ID LIST"

You can set the following lists and reports to print automatically:

- "AUTO JOURNAL"
 - See feature #22 on page 51 for details.
- "AUTO CALL. LIST"
 - See feature #26 on page 52 for details.

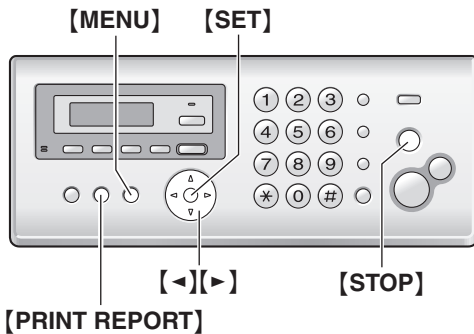

- 1 [PRINT REPORT]
- 2 Press [◀] or [▶] repeatedly to display the desired item.
- 3 [SET]
 - If you select to print out a list or a report, printing will start.
To stop printing, press [STOP].
 - If you select "AUTO JOURNAL" or "AUTO CALL. LIST", press [0] or [1] to select the desired setting, then press [SET].
[0] "OFF"
[1] "ON"
- 4 [MENU]

13.2 Specifications

13.2.1 Base unit

- **Applicable lines:**
Public Switched Telephone Network
- **Document size:**
Max. 216 mm in width, Max. 600 mm in length
- **Effective scanning width:**
208 mm
- **Effective printing width:**
A4: 202 mm
- **Transmission time^{*1}:**
Approx. 12 s/page (ECM-MMR)^{*2}
- **Scanning density:**
Horizontal: 8 pels/mm
Vertical: 3.85 lines/mm – in standard resolution,
7.7 lines/mm – in fine/photo resolution,
15.4 lines/mm – in super fine resolution
- **Photo resolution:**
64-level
- **Scanner type:**
Contact Image Sensor
- **Printer type:**
Thermal Transfer on plain paper
- **Data compression system:**
Modified Huffman (MH), Modified READ (MR), Modified Modified READ (MMR)
- **Modem speed:**
9,600 / 7,200 / 4,800 / 2,400 bps; Automatic Fallback
- **Operating environment:**
5 °C – 35 °C, 20 % – 80 % RH (Relative Humidity)
- **Dimensions:**
Approx. height 106 mm × width 367 mm × depth 200 mm
- **Mass (Weight):**
Approx. 2.8 kg
- **Power consumption:**
Standby: Approx. 2.5 W
Transmission: Approx. 15 W
Reception: Approx. 40 W (When receiving a 20 % black document)
Copy: Approx. 40 W (When copying a 20 % black document)
Maximum: Approx. 135 W (When copying a 100 % black document)
- **Power supply:**
220 V – 240 V AC, 50/60 Hz
- **Fax memory capacity^{*3}:**
Approx. 25 pages of memory transmission
Approx. 28 pages of memory reception
(Based on the ITU-T No. 1 Test Chart in standard resolution, without using the Error Correction Mode.)
- **Voice memory capacity^{*4}:**
Approx. 15 minutes of recording time

■ Copy memory capacity:

Approx. 10 pages (Based on the ITU-T No. 1 Test Chart in fine resolution.)

- *1 Transmission speed depends upon the contents of the pages, resolution, telephone line conditions and capability of the other party's machine.
- *2 Transmission speed is based upon the ITU-T No. 1 Test Chart. If the capability of the other party's machine is inferior to your unit, the transmission time may be longer.
- *3 If an error occurs during fax reception, such as a paper jam or if the recording paper runs out, the fax and subsequent faxes will be retained in memory.
- *4 Recording time may be reduced by the calling party's background noise.

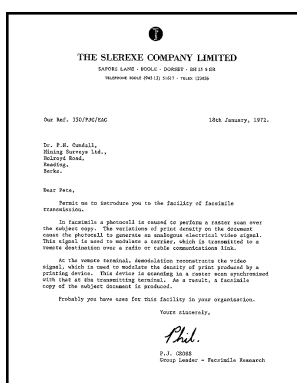
ITU-T No. 1 Test Chart**Note:**

- Design and specifications are subject to change without notice.
- The pictures and illustrations in these instructions may vary slightly from the actual product.

Recording paper specifications**Recording paper size:**

A4: 210 mm × 297 mm

Recording paper weight:

64 g/m² to 80 g/m²

Note for recording paper:

- Do not use the following types of paper:
 - Paper with a cotton and/or fibre content that is over 20 %, such as letterhead paper or paper used for resumes
 - Extremely smooth or shiny paper, or paper that is highly textured
 - Coated, damaged or wrinkled paper
 - Paper with foreign objects attached, such as tabs or staples
 - Paper which has dust, lint or oil stains
 - Paper that will melt, vaporize, discolour, scorch or emit dangerous fumes near 200 °C, such as vellum paper. These materials may transfer onto the fusing roller and cause damage.

– Moist paper

- Some paper only accepts print on one side. Try using the other side of the paper if you are not happy with the print quality or if misfeeding occurs.
- For proper paper feeding and best print quality, we recommend using long-grained paper.
- Do not use paper of different types or thickness at the same time. This may cause a paper jam.
- Avoid double-sided printing.
- Do not use paper printed from this unit for double-sided printing with other copiers or printers. This may cause a paper jam.
- To avoid curling, do not open paper packs until you are ready to use the paper. Store unused paper in the original packaging, in a cool and dry location.

13.2.2 Cordless handset**■ Standard:**

DECT (Digital Enhanced Cordless Telecommunications)
GAP (Generic Access Profile)

■ Number of channels:

120 Duplex Channels

■ Frequency range:

1.88 GHz to 1.9 GHz

■ Duplex procedure:

TDMA (Time Division Multiple Access)

■ Channel spacing:

1,728 kHz

■ Bit rate:

1,152 kbit/s

■ Modulation:

GFSK (Gaussian Frequency Shift Keying)

■ RF transmission power:

Approx. 250 mW

■ Voice coding:

ADPCM 32 kbit/s

■ Operating environment:

5 °C – 40 °C, 20 % – 80 % RH (Relative Humidity)

■ Dimensions:

Approx. height 155 mm × width 48 mm × depth 34 mm

■ Mass (Weight):

Approx. 140 g

13.2.3 Charger unit**■ Operating environment:**

5 °C – 40 °C, 20 % – 80 % RH (Relative Humidity)

■ Dimensions:

Approx. height 61 mm × width 87 mm × depth 95 mm

■ Mass (Weight):

Approx. 90 g

■ Power consumption:

Standby: Approx. 1.5 W

Maximum: Approx. 3 W

■ Power supply:

AC adaptor (220 V – 240 V AC, 50/60 Hz)

14.1 Index

- # #01 Date and time: 20
- #02 Your logo: 21
- #03 Your fax number: 21
- #04 Sending report: 35
- #06 FAX ring count: 50
- #06 TAM ring count: 40
- #10 Caller's recording time: 51
- #11 Remote operation ID: 51
- #17 External ringtone: 51
- #22 Automatic journal report: 35
- #23 Overseas mode: 51
- #25 Delayed send: 52
- #26 Automatic Caller ID list: 52
- #31 Distinctive Ring: 42
- #34 Quick scan: 35, 43
- #35 Night mode: 25
- #36 Receiving reduction: 53
- #39 LCD display contrast: 53
- #41 Fax activation code: 53
- #44 Memory reception alert: 53
- #46 Friendly reception: 53
- #49 Auto disconnection: 54
- #54 Greeting time: 54
- #58 Scan contrast: 54
- #59 Copy phonebook: 61
- #67 Call screening: 54
- #68 ECM selection: 54
- #72 Recall/flash time: 55
- #76 Connecting tone: 55
- #77 Auto answer: 55
- #80 Set default: 55
- A** Accessories: 9
 - Paper tray: 15
 - Additional base units: 59
 - Additional cordless handsets: 59
 - Advanced features: 51
 - Alarm: 58
 - Auto answer setting: 55
 - Auto disconnection: 54
 - Auto talk feature: 23
- B** Base unit
 - Cancelling: 59
 - Selecting: 59
 - Base unit phonebook
 - Copying: 61
 - Editing: 27
 - Erasing: 27
 - Making a phone call: 26
 - Sending faxes: 36
 - Storing: 26
 - Basic features: 50
 - Battery
 - Charge: 18
 - Installation: 16
 - Performance: 18
 - Replacement: 16
 - BROADCAST LIST: 78
 - Broadcast transmission: 37
 - Button description
 - Base unit: 10
 - Cordless handset: 11
- C** Caller ID
 - Calling back: 29
 - Storing: 31
 - CALLER ID LIST: 29, 52, 78
 - Caller's recording time: 51
 - Call restriction: 58
 - Call screening: 48, 54
 - Call waiting: 24, 29
 - Category: 25
 - Display colours: 29
 - Ringtones: 29
 - Chain dial: 26
 - Character entry: 62
 - Cleaning: 76
 - Conference calls: 60
 - Connecting tone: 55
 - Connections: 17
 - Copy: 43
 - Collation: 43
 - Enlarge/Reduce: 43
 - Cordless handset
 - Cancelling: 59
 - Locator: 60
 - Power ON/OFF: 18
 - Registration: 59
 - Cordless handset phonebook
 - Copying: 61
 - Editing: 26
 - Erasing: 26
 - Making a phone call: 26
 - Storing: 25
- D** Date and time: 20
- Delayed send: 52
- Display (Base unit)
 - Contrast: 56
 - Error messages: 65
- Display (Cordless handset)
 - Colour: 56
 - Contrast: 56
 - Error messages: 66
 - Icons: 11
 - Language: 58
 - Standby mode: 56
 - Wallpaper: 56
- Distinctive Ring service: 42
- Document size: 36
- E** ECM selection: 54
- Error messages: 64
- Extension telephone: 39
- F** Fax activation code: 53
- Fax number: 21

- FAX ONLY mode: 38, 40
- Fax Stream Duet: 42
- Flash time: 55
- Friendly reception: 53
- G** Greeting message
 - TAM/FAX: 45Greeting message time
 - TAM/FAX: 54
- I** Ink film: 14
- Intercom: 60
- J** Jams
 - Document: 75
 - Recording paper: 74JOURNAL REPORT: 35, 78
- Junk fax prohibitor: 41
- K** Key lock: 22
- Keytones: 56
- L** Language: 56
- Listening to recorded messages: 46, 48
- Logo: 21
- M** Memo message: 46
- Memory reception alert: 53
- Memory redial: 22
- Message alert: 56
- Missed calls: 29
- N** Night mode
 - Base unit: 25
 - Cordless handset: 24
- O** One touch
 - Base unit: 27
 - Cordless handset: 27Overseas mode: 51
- P** Phonebook
 - Base unit: 26
 - Cordless handset: 25
 - Sending faxes: 36PHONEBOOK LIST: 78
- PIN
 - Base unit: 57Polling: 41
- Power failure: 73
- Power ON/OFF (Cordless handset): 18
- PRINTER TEST: 78
- Programming
 - Base unit programming: 50
 - Cordless handset programming: 56
- Q** Quick scan: 35, 43
- R** Recall time: 55
- Receiving alert: 53
- Receiving faxes
 - Automatically: 40
 - Manually: 39
- Receiving reduction: 53
- Recording
 - Greeting message: 45, 47
 - Memo message: 46
 - Telephone conversation: 24
- Recording paper: 16, 79
- Recording time
 - Incoming message: 48, 51
 - TAM/FAX greeting: 54
- Redialling
 - Base unit: 23, 35, 36
 - Cordless handset: 22
- Redial list: 22
- Registration: 59
- Remote operation: 48
- Remote operation ID: 48, 51
- Reports
 - Broadcast programming: 78
 - Broadcast sending: 37
 - Caller ID: 78
 - Journal: 35, 78
 - Phonebook: 78
 - Power down: 73
 - Printer test: 78
 - Sending: 35
 - Setup: 78
- Reset (Base unit): 55
- Resolution: 43
- Ring count
 - FAX ONLY: 50
 - TAM/FAX: 48, 50
- Ringtone
 - Base unit: 51
 - Cordless handset: 56
- S** Scan contrast: 54
- Screen saver mode: 18
- Sending faxes
 - Base unit one touch dial: 36
 - Base unit phonebook: 36
 - Broadcast: 37
 - From memory: 35
 - Manually: 35
- Sending report: 35
- SETUP LIST: 78
- SMS feature: 31
- Soft keys: 11
- Storing
 - Broadcast: 37
 - One touch: 27
 - Phonebook: 25, 26
- T** TAM/FAX mode: 38, 40
- TEL mode: 38, 39
- Transferring a call: 60
- V** Voice enhancer: 22
- Voice time/day stamp: 46
- Volume
 - Base unit: 19
 - Cordless handset: 19

Notes

Notes



Sales Department:

Panasonic Australia Pty. Limited

Austlink Corporate Park, 1 Garigal Road, Belrose, NSW 2085,
Australia

Manufacturer:

Panasonic Communications (Malaysia) Sdn. Bhd.

PLO No.1, Kawasan Perindustrian Senai, KB No. 104, 81400 Senai, Negeri Johor Darul Ta'zim, Malaysia

Global web site:

<http://panasonic.net>

Copyright:

- This material is copyrighted by Panasonic Communications Co., Ltd., and may be reproduced for internal use only. All other reproduction, in whole or in part, is prohibited without the written consent of Panasonic Communications Co., Ltd.

© 2006 Panasonic Communications Co., Ltd. All Rights Reserved.



FC255AL

PFQX2639ZA CM0706PJ0